

给水 UPVC 管材 / 管件 / 阀门

UPVC PIPE / FITTING / VALVE
FOR WATER SUPPLY



CONTENTS

目录

ABOUT US 关于我们	01
CERTIFICATIONS 资质证书	03
PRODUCT CATEGORY 产品类别	05
APPLICATION 行业应用	06

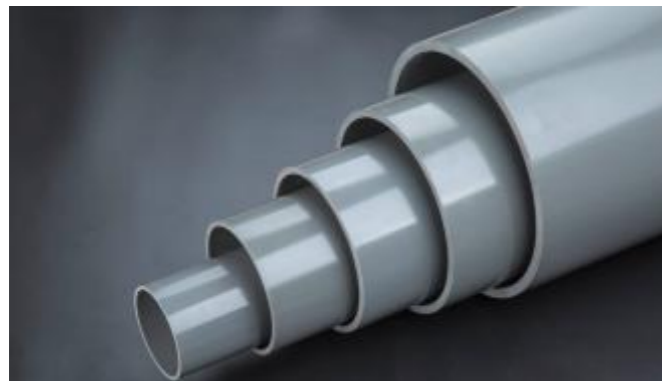

PIPES 管材	07
给水 UPVC 管材系列和规格尺寸 SERIES AND SIZE OF PIPE FOR WATER SUPPLY	08
UPVC/CPVC 管材管件执行标准一览表 Table of Product Standards-UPVC/CPVC Pipes and Fittings	09
UPVC 管材管件执行标准一览表 Standards of UPVC Testing Material	09
CPVC 材料试验标准 Standards of CPVC Testing Material	10



PIPE FITTINGS 管件

承插 22.5° 弯头 Elbow 22.5°(F/S)	12
双承 22.5° 弯头 Elbow 22.5°(F/F)	13
承插 45° 弯头 Elbow 45°(F/S)	14
双承 45° 弯头 Elbow 45°(F/F)	15
45° 弯头 Elbow 45°	16
全塑内螺纹 90° 弯头 Threaded Elbow 90°	17
承插 90° 弯头 Elbow 90°(F/S)	18
双承 90° 弯头 Elbow 90°(F/F)	19
铜内丝 90° 弯头 Copper Threaded Elbow 90°	20
90° 弯头 Elbow 90°	21
平承插三通 Tee With Flanged Branch(F/S)	22
两承一平三通 Tee With Flanged Branch(F/F)	23
两承一插三通 Tee(F/F/S)	24
三承三通 Tee(F/F/F)	25
丝孔承插三通 Tee With Copper Threaded(F/S)	27
铜内丝三通 Copper Threaded Tee	28
正三通 Tee	29

两承一插斜三通 Y-Tee	30
异三通 Reducing Tee	31
两承两插斜四通 Lateral Cross(F/F/S/S)	33
双承异径 Reducer(F/F)	34
异径 Reducer	35
铜内丝螺纹管堵 Copper Threaded Cap	37
管堵 Cap	38
双承管箍 Coupling(F/F)	39
铜内丝直接 Copper Threaded Reducer	40
管箍 Coupling	41
管卡 Bracket	42
由任 (由令) Union	43
变径 (补芯) Bushing	44
内丝 Female Adaptor	45
外丝 Male Adaptor	46
双头外丝 Male Adaptor(T/T)	47
承口法兰 Faucet Flange	48
插口法兰 Spigot Flange	49
单片式法兰 One-piece Flange	50

双片式法兰 (活套) Vanstone Flange	51
丝口盲法兰 Copper Threaded Blind Flange	52
盲法兰 Blind Flange	53
抢修节 (普通式) Compression Coupling	54
多功能抢修节 (哈夫式) Saddle Repaired Coupling	55
抢修节 (活套式) Repaired Coupling	56
增接口 Saddle Clamp	57



VALVES 阀门	59
插口球阀 SOCKET BALL VALVE	61
丝口球阀 THREADED BALL VALVE	63
手动通用蝶阀 GENERAL BUTTERFLY VALVE (HANDLED TYPE)	65

Professional strength builds easy life

专业实力构筑轻松生活

华生管道
HUASHENG PIPELINE

ABOUT US

关于我们

给水 UPVC 管材 / 管件 / 阀门

UPVC PIPE / FITTING / VALVE
FOR WATER SUPPLY

EXPERT IN PIPING SYSTEM

管路系统的专家级工厂

重信求实 华生企业的灵魂
开拓创新 永恒发展的动力

以质取胜、以质取信，为顾客提供满意的产品和服务。



▶ 公司简介

华生管道科技有限公司始建于1988年，坐落于江苏常州高新技术产业开发区，是一家集UPVC、CPVC、PE、PPH、PVDF等材质的工业、给水、环保水处理设备类塑料管道产品研发、制造于一体的管路系统专业生产企业。经过多年的探索与提升，目前华生已成为行业内的领先企业，是江苏省塑料管道系统工程技术中心依托单位，中国塑料加工工业协会、塑料管道专业委员会成员单位，中国电子材料行业协会成员单位，中国氯碱工业协会成员单位，中国电子电路行业协会成员单位。

▶ 公司实力

公司占地面积20万平方米，拥有固定资产6亿元人民币。公司现有员工400多人，下设模具事业部、管路系统事业部、精密注塑事业部，原料混配系统6套，造粒生产线8条，管材挤出生产线30条，注塑机200多台，大型加工中心等机械加工设备80多台，年生产能力达60000吨。

▶ 资质 & 荣誉

目前公司已经通过ISO9001、ISO14001、OHSAS18001等体系的认证，以及美国卫生基金国际组织NSF认证。公司被认定为江苏省高新技术企业，“华生”商标荣获江苏省著名商标。拥有江苏省高新技术产品2项，授权专利30项，获得国家质量监督检验检疫总局颁发的《中华人民共和国特种设备制造许可证（压力管道元件）》和江苏省卫计委颁发的《涉水产品卫生行政许可批件》，并入选《全国水利系统优秀产品招标重点推荐目录》和《全国农村水利工程材料设备产品信息年报》。

CERTIFICATIONS

资质证书

客户至上，优质高效，绿色环保，顾客满意。



PRODUCT CATEGORY

产品类别

▶ 给水、工业、环保水处理系列管材

DIN:20mm-800mm
S4/S5/S6.3/S8/S10/S12.5/S16/S20
ASTM:1/2"-24"
SCH40/SCH80



管材 / PIPE

▶ 给水、工业、环保水处理系列管件

(PN10、PN12.5、PN16)
柔性管件 (带胶圈管件) 63mm~355mm
胶粘式管件 (PN10、PN12.5、PN16) 20mm~500mm
SCH80 1/2"-16"



管件 / PIPE FITTING

▶ 阀门类

球阀 (插口、丝口)
DIN:20mm~110mm; ASTM:1/2"~4"
双由令球阀 (手柄式、气动式、电动式)
DIN:20mm~110mm; ASTM:1/2"~4"; JIS:16A~100A
蝶阀 (手柄式、齿轮式、气动式、电动式)
DIN:63mm~400mm; ASTM:2"~16"; JIS:50A~318A
隔膜阀 (法兰式、插口式、由令式)
DIN:20mm~160mm; ASTM:1/2"~6"; JIS:16A~50A
止回阀 (单由令式、双由令式、摆动式、旋启式)
DIN:20mm~160mm; ASTM:1/2"~8"; JIS:16A~100A
底阀 (由令式、摆动式)
DIN:20mm~160mm



阀门 / VALVES

APPLICATION INDUSTRY

行业应用



管路系统的专家级工厂 EXPERT IN PIPING SYSTEM



- 化工行业 · 建筑行业 · 水处理行业 · 医疗制药行业
- 电子行业 · 冶金行业 · 食品加工行业 · 农业灌溉行业



SERIES AND SIZE OF PIPE FOR WATER SUPPLY

给水 UPVC 管材系列和规格尺寸

管材介绍

管材特点

1. 物化性能优良。用 UPVC 生产的管材及管件，耐腐蚀，抗冲强度高，流体阻力小（较同口径铸铁管流量提高 30%）。耐老化，使用寿命长（据权威机构测试资料说明，使用年限为 40-50 年），是建筑排水、化工排污的理想材料。
2. 质轻实用，安装方便。重量只有同口径铸铁管的 1/7，可大大加快工程进度和降低施工费用。
3. 内壁光滑，排水流畅，管道不易堵塞。检查口设计独特，检查操作方便，不需要任何工具。
4. 节约建筑费用。使用 UPVC 管比使用同样规格的铸铁管的综合造价低，维修费用低。

产品参数

GB/T10002.1-2006 单位：毫米 unit:mm

公称外径 De Nominal Outside Diameter Dn	公称压力 Nominal Pressure PN(kg/cm ²)													
	0.63MPa S16		0.80MPa S12.5		1.00MPa S10		1.25MPa S8		1.60MPa S6.3		2.0MPa S5		2.5MPa S4	
	e _{min}	公差 Tolerance	e _{min}	公差 Tolerance	e _{min}	公差 Tolerance	e _{min}	公差 Tolerance	e _{min}	公差 Tolerance	e _{min}	公差 Tolerance	e _{min}	公差 Tolerance
20	-	-	-	-	-	-	-	-	2.0	0.4	2.0	0.4	2.3	0.5
25	-	-	-	-	-	-	2.0	0.4	2.0	0.4	2.3	0.5	2.8	0.5
32	-	-	-	-	2.0	0.4	2.0	0.4	2.4	0.5	2.9	0.5	3.6	0.6
40	2.0	0.4	2.0	0.4	2.0	0.4	2.4	0.5	3.0	0.5	3.7	0.6	4.5	0.7
50	2.0	0.4	2.0	0.4	2.4	0.5	3.0	0.5	3.7	0.6	4.6	0.7	5.6	0.9
63	2.0	0.4	2.5	0.5	3.0	0.5	3.8	0.6	4.7	0.8	5.8	0.9	7.1	1.1
75	2.3	0.5	2.9	0.5	3.6	0.6	4.5	0.7	5.6	0.9	6.9	1.1	8.4	1.3
90	2.8	0.5	3.5	0.6	4.3	0.7	5.4	0.9	6.7	1.1	8.2	1.3	10.1	1.6

公称外径 De Nominal Outside Diameter Dn	公称压力 Nominal Pressure PN(kg/cm ²)													
	0.63MPa S20		0.8MPa S16		1.0MPa S12.5		1.25MPa S10		1.6MPa S8		2.0MPa S6.3		2.5MPa S5	
	e _{min}	公差 Tolerance	e _{min}	公差 Tolerance	e _{min}	公差 Tolerance	e _{min}	公差 Tolerance	e _{min}	公差 Tolerance	e _{min}	公差 Tolerance	e _{min}	公差 Tolerance
110	2.7	0.5	3.4	0.6	4.2	0.7	5.3	0.8	6.6	1.1	8.1	1.3	12.3	1.9
125	3.1	0.6	3.9	0.6	4.8	0.8	6.0	0.9	7.4	1.2	9.2	1.4	13.9	2.1
140	3.5	0.6	4.3	0.7	5.4	0.9	6.7	1.1	8.3	1.3	10.3	1.6	15.7	2.4
160	4.0	0.6	4.9	0.8	6.2	1.0	7.7	1.2	9.5	1.5	11.8	1.8	17.9	2.7
180	4.4	0.7	5.5	0.9	6.9	1.1	8.6	1.3	10.7	1.7	13.3	2.0	20.0	3.0
200	4.9	0.8	6.2	1.0	7.7	1.2	9.6	1.5	11.9	1.8	14.7	2.3	22.3	3.4
225	5.5	0.9	6.9	1.1	8.6	1.3	10.8	1.7	13.4	2.1	16.6	2.5	25.1	3.8
250	6.2	1.0	7.7	1.2	9.6	1.5	11.9	1.8	14.8	2.3	18.4	2.8	27.9	4.2
280	6.9	1.1	8.6	1.3	10.7	1.7	13.4	2.1	16.6	2.5	20.6	3.1	-	-
315	7.7	1.2	9.7	1.5	12.1	1.9	15.0	2.3	18.7	2.9	23.2	3.5	-	-
355	8.7	1.4	10.9	1.7	13.6	2.1	16.9	2.6	21.1	3.2	26.1	4.0	-	-
400	9.8	1.5	12.3	1.9	15.3	2.3	19.1	2.9	23.7	3.6	29.4	4.5	-	-
450	11.0	1.7	13.8	2.1	17.2	2.6	21.5	3.3	26.7	4.1	33.1	4.9	-	-
500	12.3	1.9	15.3	2.3	19.1	2.9	23.9	3.6	29.7	4.5	36.8	5.6	-	-
560	13.7	2.1	17.2	2.6	21.4	3.3	26.7	4.1	-	-	-	-	-	-
630	15.4	2.4	19.3	2.9	24.1	3.7	30.0	4.5	-	-	-	-	-	-
710	17.4	2.7	21.8	3.3	27.2	4.1	-	-	-	-	-	-	-	-
800	19.6	3.0	24.5	3.7	30.6	4.6	-	-	-	-	-	-	-	-

注 1：考虑到安全性，最小壁厚应不小于 2.0mm。The minimum wall thickness is no less than 2.0mm for security.

注 2：除了有其他规定之外，尺寸应与 GB/T10798 一致。The size should conform to GB/T10798 unless otherwise specified.

管材 PIPE

Table of Product Standards-UPVC/CPVC Pipes and Fittings

UPVC/CPVC 管材管件执行标准一览表

种类 Type	执行标准 Product Standards
UPVC 给水管件 (国标) (DIN)UPVC Fittings For Water Supply	GB/T 10002.2-2003 BS EN ISO 1452
UPVC 化工管件 (国标) (DIN)UPVC Fittings For Industry	GB/T 4219.2-2015
UPVC 牙口式美标管件 (ASTM)Threaded Type UPVC Fittings	ASTM D2464
UPVC 承插式美标管件 (ASTM)Socket Type UPVC Fittings	ASTM D2467
CPVC 化工管件 (国标) (DIN)CPVC Fittings For Industry	GB/T 18998.3-2003
CPVC 牙口式美标管件 (ASTM)Threaded Type CPVC Fittings	ASTM F437
CPVC 承插式美标管件 (ASTM)Socket Type CPVC Fittings	ASTM F439
UPVC 给水管材 (国标) (DIN) UPVC Pipes For Water Supply	GB/T 10002.1-2006
UPVC 化工管材 (国标) (DIN) UPVC Pipes For Industry	GB/T 4219.1-2008
UPVC 美标 管材 (ASTM) UPVC Pipes	ASTM D 1785
CPVC 给水管材 (国标) (DIN) CPVC Pipes For Water Supply	GB/T 18993.2-2003
CPVC 化工管材 (国标) (DIN) CPVC Pipes For Industry	GB/T 18998.2-2003
CPVC 美标管材 (ASTM) CPVC Pipes	ASTM F441

Standards of UPVC Testing Material

UPVC 材料试验标准

指标名称 Index Name	单位 Unit	指标 Index	试验方法 Test method
密度 Density	kg/m ³	1330-1460	按 GB/T 1033-1986 规定 A 法测定 Method A of GB 1033
维卡软化温度 Vicat Softening Temperature	°C	管材 ≥80, 管件 ≥74 Pipe ≥80, Fitting ≥74	GB/T 8802-2001
静液压测试 Hydraulic Test		不破裂, 不渗水 No Breakage, no leakage	GB/T 6111-2003
纵向回缩率 Longitudinal Reversion	%	≤5	GB/T 6671-2001
二氯甲烷浸泡 D1chloromethane Soakin		试样表面无损坏 No damage on surface of sampe	GB/T 13526

Standards of CPVC Testing Material

CPVC 材料试验标准

指标名称 Index Name	单位 Unit	指标 Index	试验方法 Test method
密度 Density	kg/m ³	1450-1650	GB/T 1033-1986 方法 A Method A of GB/T 1033-1986
维卡软化温度 (管材) Vicat Softening Temperature(Pipes)	°C	≥110	GB/T 8802
维卡软化温度 (管件) Vicat Softening Temperature(Fittings)	°C	≥103	GB/T 8802
纵向回缩率 Longitudinal Reversion	%	≤5	GB/T6671-2001 方法 B Method B of GB/T6671-2001
氯含量 (质量百分比) Chlorine Concentration (Mass Percent)	%	≥60	GB/T 7139
静液压试验 Hydrostatic Test	--	无脱层, 无破碎 No leafing,no break	ISO 1167:1996
静液压状态下热稳定试验 Hydrostatic Reheat Test	--	无脱层, 无破碎 No leafing,no break	ISO 1167
落锤冲击试验 Drop Impact Test	Cal/g/°C	TIR≤10%	GB/T 14152
烘箱试验 Oven Test	MPa	无分层, 无开裂 No lamination,no crack	GB/T 8803
弹性模量 * Modulus of Elasticity	MPa	≥2660	ASTM D638
拉伸强度 * Tensile Strength	KJ/m ²	≥56	ASTM D638
冲击强度 * Impact Strength	m/m°C	≥16	ASTM D256
线膨胀系数 * Coefficient of Linear Expansion	Cal/g/°C	3.4x10 ⁻⁵	--
热传导率 * Thermal Conductivity	Cal/g/°C	0.14	ASTM C177
比热 * Specific Heat	Ω/cm	0.14	--
体电阻 * Bulk Resistance	AC,KV/mm	≥1015	--
介电强度 * Dielectric Strength	--	13	--
阻燃性 * Flame Retardant	--	自熄 Self-extinguish	UL-94

ELBOW22.5°(F/S)

承插 22.5°弯头

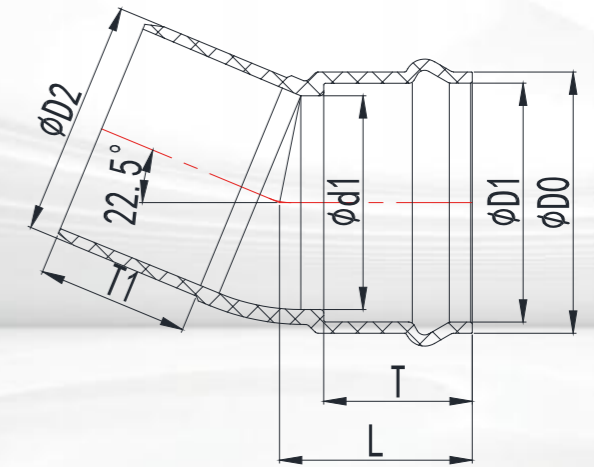

产品参数

尺寸 Size De	外形尺寸 Dimensions (mm)						
	D0	D1	D2	d1	T1	T	L
225	251.50	227.50	225.30	221.00	212.00	139.00	196.00
250	276.50	252.30	250.30	247.00	228.00	152.00	212.00
315	347.80	318.30	315.20	312.00	257.00	198.00	257.00

管件 PIPE FITTINGS

ELBOW 22.5°(F/F)

双承 22.5°弯头

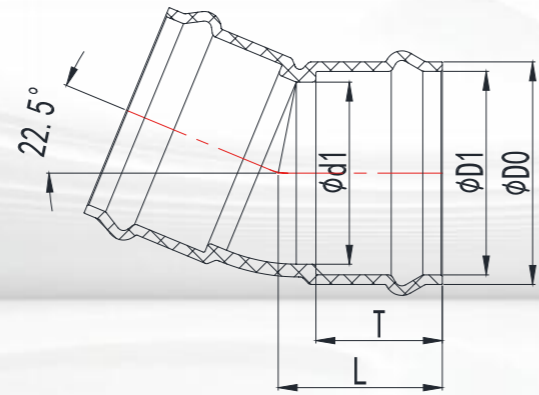

ELBOW 45°(F/S)

承插 45°弯头

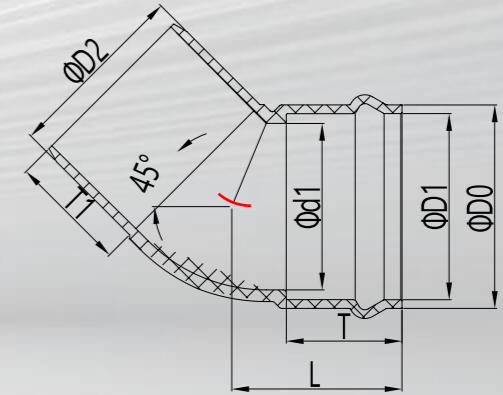

产品参数

尺寸 Size De	外形尺寸 Dimensions (mm)				
	D0	D1	d1	T	L
63	74.50	65.30	62.00	76.00	94.50
75	88.50	77.50	73.5	84.50	106.00
90	105.50	92.50	88.50	95.00	110.00
110	125.70	111.50	108.00	122.00	152.00
160	181.50	162.30	158.00	141.00	168.00
200	225.00	202.50	197.00	152.00	178.50
225	251.50	227.50	221.00	139.00	196.00
250	276.50	252.30	247.00	152.00	212.00
315	347.80	318.30	312.00	198.00	257.00

产品参数

尺寸 Size De	外形尺寸 Dimensions (mm)						
	D0	D1	D2	d1	T1	T	L
200	225.00	202.50	200.20	197.00	223.00	152.00	202.00
225	251.50	227.50	225.30	221.00	212.00	139.00	215.00
250	276.50	252.30	250.30	247.00	252.00	152.00	236.00
315	347.80	318.30	315.20	312.00	291.30	198.00	291.30

ELBOW 45°(F/F)

双承 45°弯头

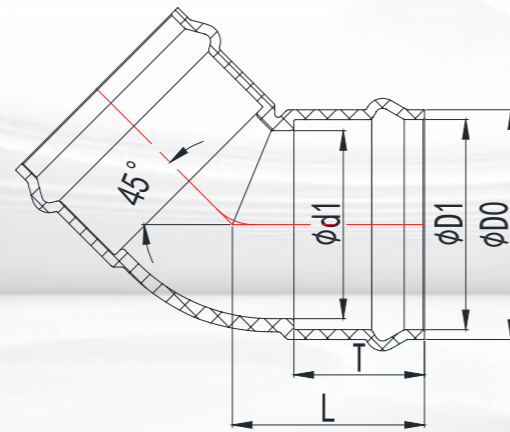

ELBOW 45°

45°弯头

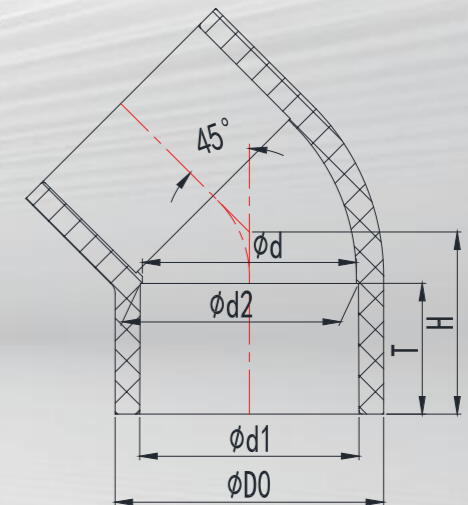

产品参数

尺寸 Size De	外形尺寸 Dimensions (mm)				
	D0	D1	d1	T	L
63	74.50	65.30	62.00	76.00	96.00
75	88.50	77.50	73.50	84.50	110.00
90	105.50	92.50	88.50	95.00	122.50
110	125.70	111.50	108.00	122.00	152.00
160	181.50	162.30	158.00	141.00	183.50
200	225.00	202.50	197.00	152.00	203.00
225	251.50	227.50	221.00	139.00	217.00
250	276.50	252.30	247.00	152.00	236.00
315	347.80	318.30	312.00	198.00	291.00
355	388.50	356.63	326.00	235.00	315.00

产品参数

尺寸 Size De	外形尺寸 Dimensions (mm)						公称压力 Nominal Pressure PN(kg/cm ²)
	D0	d1	d2	d	T	H	
20	24.60	20.24	19.96	19.00	17.00	22.14	10
25	29.84	25.24	24.95	24.00	19.50	25.67	10
32	37.16	32.25	31.95	31.00	23.00	30.62	10
40	46.48	40.28	39.95	39.00	27.00	36.28	10
50	57.00	50.33	49.94	49.00	32.00	43.35	10
63	70.38	63.34	62.93	62.00	38.50	52.54	10
75	83.05	75.35	74.93	73.50	44.50	61.72	10
90	99.28	90.38	89.93	88.50	52.00	72.33	10
110	120.40	110.42	109.92	108.00	62.00	87.50	10
125	135.00	125.52	124.93	123.00	69.50	98.00	10
140	153.10	140.58	139.88	138.00	77.00	108.60	10
160	174.52	160.62	159.87	158.00	87.00	122.70	10
180	202.60	180.81	179.91	178.50	97.00	137.87	10
200	217.40	200.90	199.85	197.00	107.00	108.40	10
225	243.58	226.02	224.83	221.00	119.50	168.70	10
250	270.90	251.15	249.41	247.00	132.00	193.30	10
280	314.80	281.46	280.16	278.00	147.00	209.60	10
315	344.50	316.55	315.05	312.00	165.00	233.50	10
355	386.20	356.63	355.03	326.00	183.50	272.80	6
400	433.80	401.60	400.00	398.50	208.00	298.52	6

THREADED ELBOW 90°

全塑内螺纹 90°弯头

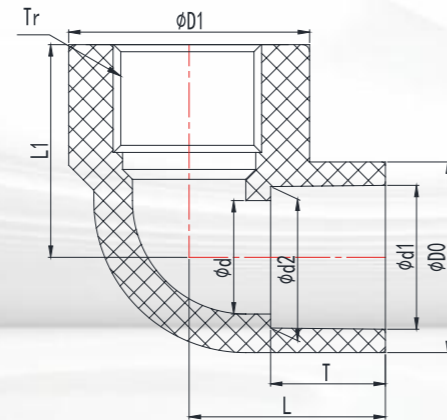

产品参数

尺寸 Size De	外形尺寸 Dimensions (mm)									公称压力 Nominal Pressure PN(kg/cm ²)
	D0	D1	d1	d2	d	T	L1	L	Tr 螺纹	
20*1/2"	25.80	34.00	20.24	19.96	18.00	17.00	32.00	33.00	1/2"	10
25*3/4"	31.66	42.10	25.24	24.95	24.00	19.50	33.00	39.00	3/4"	10

ELBOW 90°(F/S)

承插 90°弯头

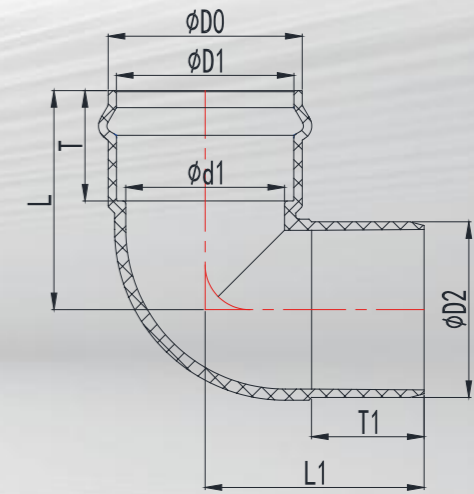

产品参数

尺寸 Size De	外形尺寸 Dimensions (mm)							
	D0	D1	D2	d1	T1	T	L1	L
200	225.00	202.50	200.20	197.00	223.00	152.00	285.00	270.00
225	251.50	227.50	225.30	221.00	212.00	139.00	304.00	288.00
250	276.50	252.30	250.30	247.00	252.00	152.00	328.00	312.00
315	347.80	318.30	315.20	312.00	291.30	198.00	393.00	393.00

ELBOW 90°(F/F)

双承 90°弯头

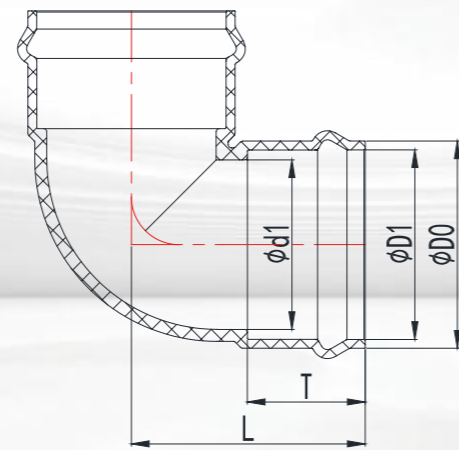

COPPER THREADED ELBOW 90°

铜内丝 90°弯头

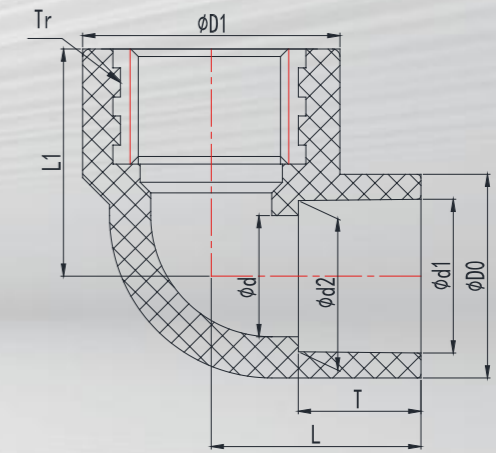

产品参数

尺寸 Size De	外形尺寸 Dimensions (mm)				
	D0	D1	d1	T	L
63	74.50	65.30	62.00	76.00	110.00
75	88.50	77.50	73.50	84.50	125.75
90	105.50	92.50	88.50	95.00	142.50
110	125.70	111.50	108.00	122.00	188.50
160	181.50	162.30	158.00	141.00	236.50
200	225.00	202.50	197.00	152.00	270.00
225	251.50	227.50	221.00	139.00	288.00
250	276.50	252.30	247.00	152.00	312.00
315	347.80	318.30	312.00	198.00	393.00
355	388.50	356.63	326.00	235.00	410.00

产品参数

尺寸 Size De	外形尺寸 Dimensions (mm)									公称压力 Nominal Pressure PN(kg/cm ²)
	D0	D1	d1	d2	d	T	L1	L	Tr 螺纹	
20*1/2"	24.70	32.00	20.24	19.96	18.00	17.00	30.80	28.50	1/2"	10
25*1/2"	29.70	32.00	25.24	24.95	24.00	19.50	33.15	33.00	1/2"	10
25*3/4"	29.70	37.10	25.24	24.95	24.00	19.50	33.15	34.84	3/4"	10
32*1/2"	37.30	32.00	32.25	31.95	18.80	23.00	39.35	42.00	1/2"	10
32*3/4"	37.30	37.00	32.25	31.95	24.00	23.00	45.35	42.50	3/4"	10
32*1"	37.30	44.30	32.25	31.95	31.00	23.00	41.35	39.85	1"	10

ELBOW 90°

90°弯头

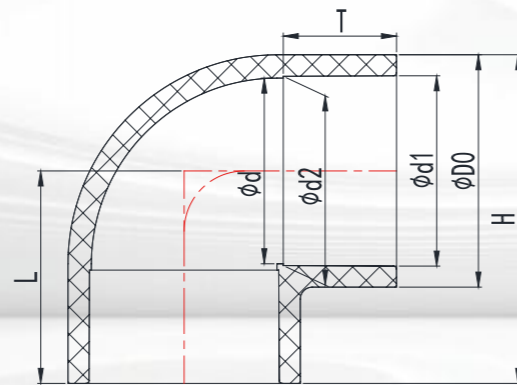

产品参数

尺寸 Size De	外形尺寸 Dimensions (mm)							公称压力 Nominal Pressure PN(kg/cm ²)
	D0	d1	d2	d	T	L	H	
20	24.48	20.24	19.96	19.00	17.00	28.50	40.74	10
25	30.18	25.24	24.95	24.00	19.50	33.50	48.59	10
32	37.14	32.25	31.95	31.00	23.00	40.50	59.07	10
40	46.56	40.28	39.95	39.00	27.00	48.50	71.78	10
50	57.10	50.33	49.94	49.00	32.00	58.50	87.05	10
63	71.18	63.34	62.93	62.00	38.50	71.50	107.09	10
75	84.34	75.35	74.93	73.50	44.50	83.25	125.42	10
90	99.10	90.38	89.93	88.50	52.00	98.25	147.80	10
110	120.40	110.42	109.92	108.00	62.00	118.00	178.20	10
125	135.50	125.52	124.93	123.00	69.50	118.50	186.25	10
140	153.10	140.58	139.88	138.00	77.00	149.00	225.55	10
160	175.00	160.62	159.87	158.00	87.00	169.00	256.50	10
180	202.50	180.81	179.91	178.50	97.00	190.00	291.25	10
200	219.30	200.90	199.85	197.00	107.00	211.00	320.65	10
225	243.30	226.02	224.83	221.00	119.50	235.50	357.15	10
250	271.40	251.15	249.41	247.00	132.00	261.00	396.70	10
280	314.80	281.46	280.16	278.00	147.00	276.00	433.40	10
315	344.50	316.55	315.05	312.00	165.00	326.50	498.75	10
355	385.00	356.63	355.03	326.00	183.50	368.25	560.75	6
400	432.70	401.60	400.00	398.50	208.00	413.00	629.35	6

TEE WITH FLANGED BRANCH (F/S)

平承插三通

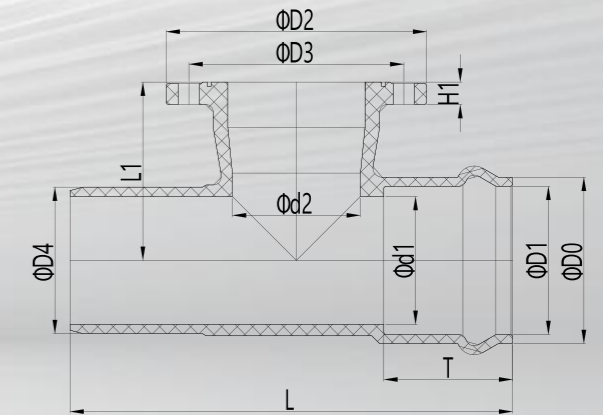

产品参数

尺寸 Size De	外形尺寸 Dimensions (mm)											
	D0	D1	D2	D3	D4	d1	d2	T	H1	L1	L	螺孔数 n
110	125.70	111.50	224.00	180.00	110.20	108.00	108.00	122.00	19.00	160.00	405.00	8
160	181.50	162.30	284.00	240.00	160.30	158.00	158.00	141.00	23.00	195.00	485.00	8
200	225.00	202.50	338.00	295.00	200.20	197.00	197.00	152.00	26.00	230.00	555.00	8
225	251.50	227.50	344.00	295.00	225.30	221.00	221.00	139.00	29.50	255.00	595.00	8
250	276.50	252.30	394.00	350.00	250.30	247.00	247.00	152.00	31.50	280.00	640.00	12
315	347.80	318.30	443.00	400.00	315.20	312.00	312.00	198.00	36.00	330.00	785.00	12
160*110	181.50	162.30	224.00	180.00	160.30	158.00	108.00	141.00	19.00	192.00	450.00	8
200*110	225.00	202.50	224.00	180.00	200.20	197.00	108.00	152.00	19.00	215.00	495.00	8
200*160	225.00	202.50	284.00	240.00	200.20	197.00	158.00	152.00	23.00	220.00	515.00	8
225*110	251.50	227.50	224.00	180.00	225.30	221.00	108.00	139.00	19.00	233.50	485.00	8
225*160	251.50	227.50	284.00	240.00	225.30	221.00	158.00	139.00	23.00	245.00	520.00	8
250*110	276.50	252.30	224.00	180.00	250.30	247.00	108.00	152.00	19.00	257.00	515.00	8
250*160	276.50	252.30	284.00	240.00	250.30	247.00	158.00	152.00	23.00	257.00	538.00	8
250*200	276.50	252.30	338.00	295.00	250.30	247.00	197.00	152.00	26.00	268.50	555.00	8
315*110	347.80	318.30	224.00	180.00	315.20	312.00	108.00	198.00	19.00	277.50	595.00	8
315*160	347.80	318.30	284.00	240.00	315.20	312.00	158.00	198.00	23.00	288.50	625.00	8
315*200	347.80	318.30	338.00	295.00	315.20	312.00	197.00	198.00	26.00	299.00	660.00	8

TEE WITH FLANGED BRANCH(F/F)

两承一平三通

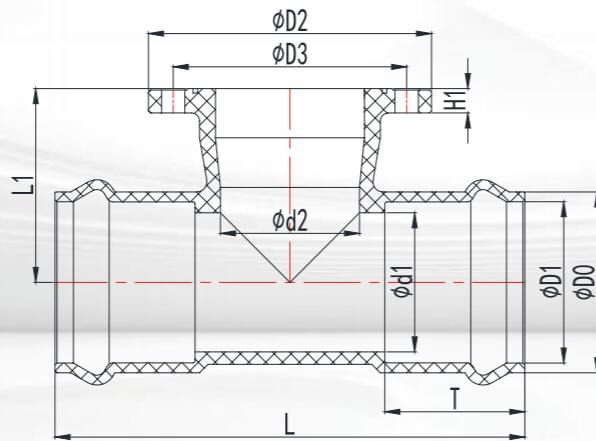

TEE(F/F/S)

两承一插三通

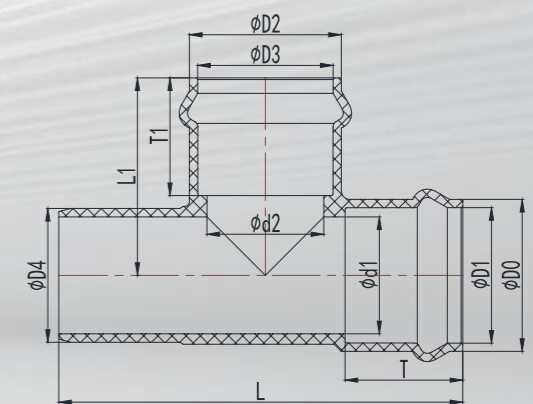

产品参数

尺寸 Size De	外形尺寸 Dimensions (mm)										
	D0	D1	D2	D3	d1	d2	T	H1	L1	L	螺孔数 n
110	125.70	111.50	224.00	180.00	108.00	108.00	122.00	19.00	160.00	405.00	8
160	181.50	162.30	284.00	240.00	158.00	158.00	141.00	23.00	195.00	473.00	8
200	225.00	202.50	338.00	295.00	197.00	197.00	152.00	26.00	230.00	540.00	8
225	251.50	227.50	344.00	295.00	221.00	221.00	139.00	29.50	255.00	576.00	8
250	276.50	252.30	394.00	350.00	247.00	247.00	152.00	31.50	280.00	624.00	12
315	347.80	318.30	443.00	400.00	312.00	312.00	198.00	36.00	330.00	788.00	12
160*110	181.50	162.30	224.00	180.00	158.00	108.00	141.00	19.00	192.00	446.00	8
200*110	225.00	202.50	224.00	180.00	197.00	108.00	152.00	19.00	215.00	488.00	8
200*160	225.00	202.50	284.00	240.00	197.00	158.00	152.00	23.00	220.00	500.00	8
225*110	251.50	227.50	224.00	180.00	221.00	108.00	139.00	19.00	233.50	466.00	8
225*160	251.50	227.50	284.00	240.00	221.00	158.00	139.00	23.00	245.00	504.00	8
250*110	276.50	252.30	224.00	180.00	247.00	108.00	152.00	19.00	245.50	500.00	8
250*160	276.50	252.30	284.00	240.00	247.00	158.00	152.00	23.00	257.00	538.00	8
250*200	276.50	252.30	338.00	295.00	247.00	197.00	152.00	26.00	268.50	578.00	8
315*110	347.80	318.30	224.00	180.00	312.00	108.00	198.00	19.00	277.50	592.00	8
315*160	347.80	318.30	284.00	240.00	312.00	158.00	198.00	23.00	288.50	626.00	8
315*200	347.80	318.30	338.00	295.00	312.00	197.00	198.00	26.00	299.00	667.00	8

产品参数

尺寸 Size De	外形尺寸 Dimensions (mm)										
	D0	D1	D2	D3	D4	d1	d2	T1	T	L1	L
110	125.70	111.50	125.70	111.50	110.20	108.00	108.00	122.00	122.00	202.50	405.00
160	181.50	162.30	181.50	162.30	160.30	158.00	158.00	141.00	141.00	236.50	485.00
200	225.00	202.50	225.00	202.50	200.20	197.00	197.00	152.00	152.00	270.00	555.00
225	251.50	227.50	251.50	227.50	225.30	221.00	221.00	139.00	139.00	288.00	595.00
250	276.50	252.30	276.50	252.30	250.30	247.00	247.00	152.00	152.00	312.00	640.00
315	347.80	318.30	347.80	318.30	315.20	312.00	312.00	198.00	198.00	393.00	785.00
160*110	181.50	162.30	125.70	111.50	160.30	158.00	108.00	122.00	141.00	220.00	450.00
200*110	225.00	202.50	125.70	111.50	200.20	197.00	108.00	122.00	152.00	240.00	495.00
200*160	225.00	202.50	181.50	162.30	200.20	197.00	158.00	141.00	152.00	250.00	515.00
225*110	251.50	227.50	125.70	111.50	225.30	221.00	108.00	122.00	139.00	263.00	485.00
225*160	251.50	227.50	181.50	162.30	225.30	221.00	158.00	141.00	139.00	290.00	520.00
250*110	276.50	252.30	125.70	111.50	250.30	247.00	108.00	122.00	152.00	275.00	515.00
250*160	276.50	252.30	181.50	162.30	250.30	247.00	158.00	141.00	152.00	302.00	538.00
250*200	276.50	252.30	225.00	202.50	250.30	247.00	197.00	152.00	152.00	228.00	555.00
315*110	347.80	318.30	125.70	111.50	315.20	312.00	108.00	122.00	198.00	317.00	595.00
315*160	347.80	318.30	181.50	162.30	315.20	312.00	158.00	141.00	198.00	336.50	625.00
315*200	347.80	318.30	225.00	202.50	315.20	312.00	197.00	152.00	198.00	393.00	660.00

TEE(F/F/F)

三承三通

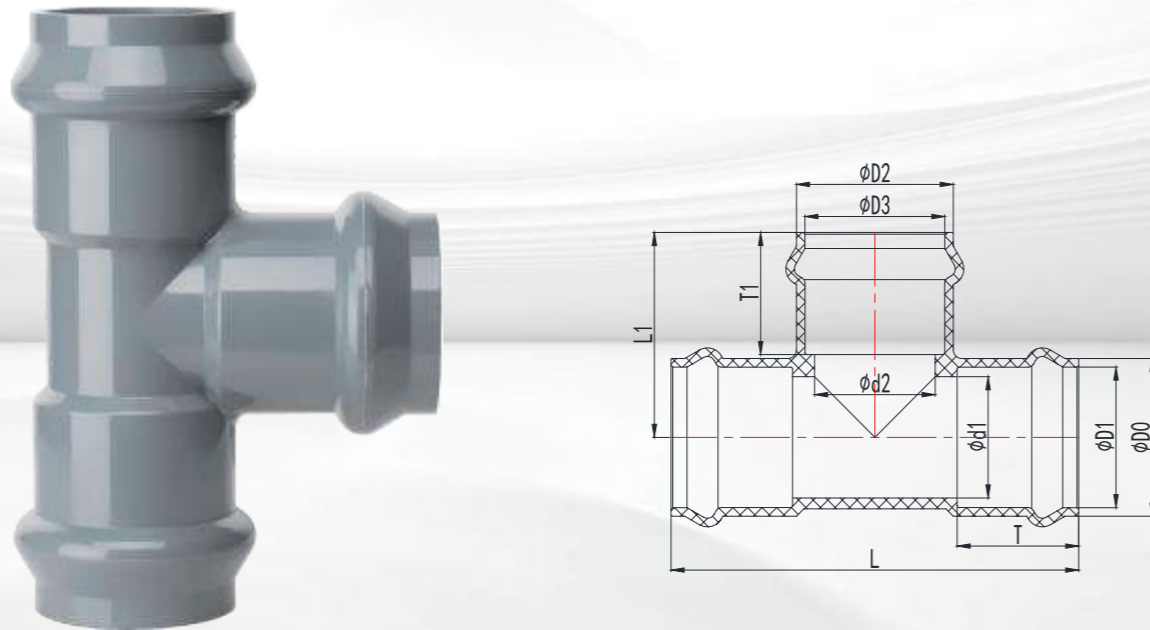

产品参数

尺寸 Size De	外形尺寸 Dimensions (mm)									
	D0	D1	D2	D3	d1	d2	T1	T	L1	L
63	74.50	65.30	74.50	65.30	62.00	62.00	76.00	76.00	110.00	220.00
75	88.50	77.50	88.50	77.50	73.50	73.50	84.50	84.50	125.00	255.00
90	105.50	92.50	105.50	92.50	88.50	88.50	95.00	95.00	142.50	285.00
110	125.70	111.50	125.70	111.50	108.00	108.00	122.00	122.00	202.50	404.00
160	181.50	162.30	181.50	162.30	158.00	158.00	141.00	141.00	236.50	470.00
200	225.00	202.50	225.00	202.50	197.00	197.00	152.00	152.00	270.00	555.00
225	251.50	227.50	251.50	227.50	221.00	221.00	139.00	139.00	288.00	592.00
250	276.50	252.30	276.50	252.30	247.00	247.00	152.00	152.00	312.00	640.00
315	347.80	318.30	347.80	318.30	312.00	312.00	198.00	198.00	393.00	786.00
355	389.00	318.30	389.00	318.30	326.00	326.00	198.00	198.00	410.00	820.00
75*63	88.50	77.50	74.50	65.30	73.50	62.00	76.00	84.50	115.00	243.00
90*63	105.50	92.50	74.50	65.30	88.50	62.00	76.00	95.00	121.40	262.20
90*75	105.50	92.50	88.50	77.50	88.50	73.50	84.50	95.00	132.90	272.20
110*63	125.70	111.50	74.50	65.30	108.00	62.00	76.00	122.00	150.00	405.00
110*75	125.70	111.50	88.50	77.50	108.00	73.50	84.50	122.00	159.50	405.00
110*90	125.70	111.50	105.50	92.50	108.00	88.50	95.00	122.00	170.00	405.00
160*63	181.50	162.30	74.50	65.30	158.00	62.00	76.00	141.00	175.00	446.00
160*75	181.50	162.30	88.50	77.50	158.00	73.50	84.50	141.00	185.00	446.00
160*90	181.50	162.30	105.50	92.50	158.00	88.50	95.00	141.00	195.00	446.00
160*110	181.50	162.30	125.70	111.50	158.00	108.00	122.00	141.00	220.00	446.00
200*63	225.00	202.50	74.50	65.30	197.00	62.00	76.00	152.00	195.00	490.00
200*75	225.00	202.50	88.50	77.50	197.00	73.50	84.50	152.00	205.00	490.00
200*90	225.00	202.50	105.50	92.50	197.00	88.50	95.00	152.00	215.00	490.00
200*110	225.00	202.50	125.70	111.50	197.00	108.00	122.00	152.00	240.00	490.00
200*160	225.00	202.50	182.00	162.30	197.00	158.00	141.00	152.00	250.00	500.00
225*110	251.50	227.50	125.70	111.50	221.00	108.00	122.00	139.00	263.00	466.00
225*160	251.50	227.50	182.00	162.30	221.00	158.00	141.00	139.00	290.00	504.00
250*110	276.50	252.30	125.70	111.50	247.00	108.00	122.00	152.00	275.00	500.00
250*160	276.50	252.30	182.00	162.30	247.00	158.00	141.00	152.00	302.00	638.00
250*200	276.50	252.30	225.00	202.50	247.00	197.00	152.00	152.00	310.00	578.00
250*225	276.50	252.30	251.50	227.50	226.00	216.00	150.00	152.00	315.00	626.00
315*110	347.80	318.30	125.70	111.50	312.00	108.00	122.00	198.00	317.00	592.00
315*160	347.80	318.30	182.00	162.30	312.00	158.00	141.00	198.00	336.50	626.00
315*200	347.80	318.30	225.00	202.50	312.00	197.00	152.00	198.00	347.00	660.00
315*225	347.80	318.30	251.50	227.50	312.00	221.00	139.00	198.00	340.00	735.00
315*250	347.80	318.30	276.50	252.30	312.00	247.00	152.00	198.00	347.00	735.00
355*110	389.00	318.30	125.70	111.50	326.00	108.00	122.00	198.00	322.50	635.00
355*160	389.00	318.30	182.00	162.30	326.00	158.00	141.00	198.00	347.50	635.00
355*200	389.00	318.30	225.00	202.50	326.00	197.00	152.00	198.00	360.00	730.00
355*225	389.00	318.30	251.50	227.50	326.00	221.00	139.00	198.00	354.00	730.00
355*250	389.00	318.30	276.50	252.30	326.00	247.00	152.00	198.00	369.00	730.00
355*315	389.00	318.30	347.80	318.30	326.00	312.00	198.00	198.00	418.00	820.00

TEE WITH COPPER THREADED(F/S)

丝孔承插三通

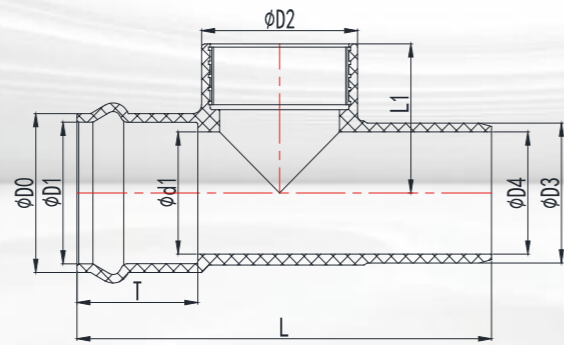

COPPER THREADED TEE

铜内丝三通

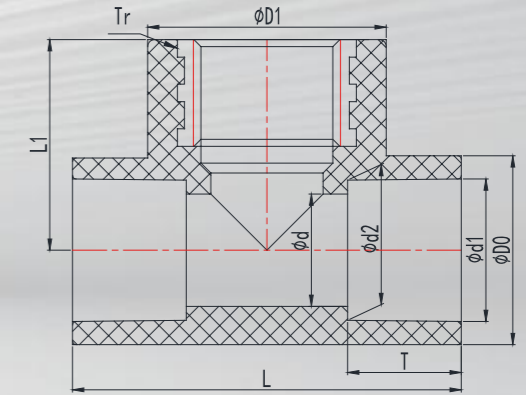

产品参数

尺寸 Size De	外形尺寸 Dimensions (mm)									
	D0	D1	D2	D3	D4	d1	T	L1	L	Tr
110*2"	125.70	111.50	80.00	110.20	79.00	108.00	122.00	79.00	335.00	2"
160*2"	181.50	162.30	80.00	160.30	140.00	158.00	141.00	102.00	375.00	2"
200*2"	225.00	202.50	80.00	200.20	178.00	197.00	152.00	123.00	410.00	2"

产品参数

尺寸 Size De	外形尺寸 Dimensions (mm)									公称压力 Nominal Pressure PN(kg/cm ²)
	D0	D1	d1	d2	d	T	L1	L	Tr 螺纹	
20*1/2"	24.50	32.00	20.24	19.96	19.00	17.00	32.00	58.00	1/2"	10
25*1/2"	29.50	32.00	25.24	24.95	24.00	19.50	35.00	60.30	1/2"	10
25*3/4"	30.00	38.10	25.24	24.95	24.00	19.50	38.00	60.70	3/4"	10
32*1/2"	37.00	32.00	32.25	31.95	31.00	23.00	38.00	67.60	1/2"	10
32*3/4"	37.00	38.00	32.25	31.95	31.00	23.00	38.00	74.10	3/4"	10
32*1"	37.00	44.00	32.25	31.95	31.00	23.00	40.00	81.00	1"	10
63*3/4"	70.00	38.00	63.34	62.93	62.00	38.50	53.00	105.70	3/4"	10
63*1"	70.00	44.00	63.34	32.93	62.00	38.50	56.00	112.00	1"	10

TEE

正三通

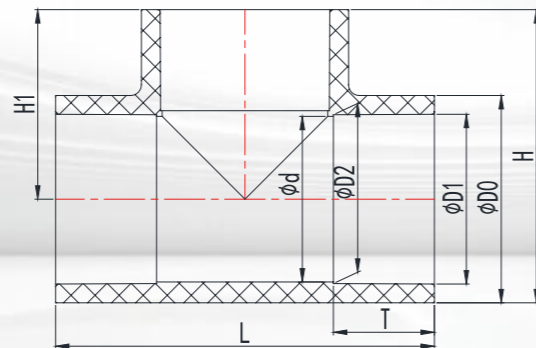

Y-TEE

两承一插斜三通

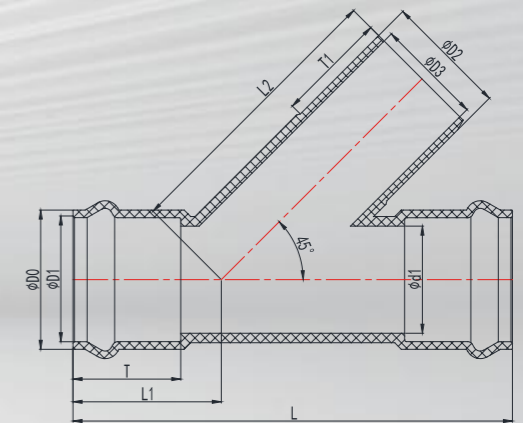

产品参数

尺寸 Size De	外形尺寸 Dimensions (mm)								公称压力 Nominal Pressure PN(kg/cm ²)
	D0	D1	D2	d	T	H1	H	L	
20	24.80	20.24	19.96	19.00	17.00	28.50	40.90	57.00	10
25	30.10	25.24	24.95	24.00	19.50	33.50	48.55	67.00	10
32	37.50	32.25	31.95	31.00	23.00	40.50	59.25	81.00	10
40	46.48	40.28	39.95	39.00	27.00	48.50	71.74	95.60	10
50	57.30	50.33	49.94	49.00	32.00	58.50	87.15	117.50	10
63	70.50	63.34	62.93	62.00	38.50	71.50	106.75	142.70	10
75	84.00	75.35	74.93	73.50	44.50	83.25	125.25	166.50	10
90	100.60	90.38	89.93	88.50	52.00	98.25	148.55	203.00	10
110	120.80	110.42	109.92	108.00	62.00	118.00	178.40	237.00	10
125	136.80	125.52	124.93	123.00	69.50	118.50	186.90	267.00	10
140	153.50	140.58	139.88	138.00	77.00	149.00	225.75	298.00	10
160	175.00	160.62	159.87	158.00	87.00	169.00	256.50	338.50	10
180	202.60	180.81	179.91	178.50	97.00	190.00	291.30	379.00	10
200	219.00	200.90	199.85	197.00	107.00	211.00	320.50	420.00	10
225	246.00	226.02	224.83	221.00	119.50	235.50	358.50	474.00	10
250	272.00	251.15	249.41	247.00	132.00	261.00	397.00	522.00	10
280	314.80	281.46	280.16	278.00	147.00	276.00	433.40	581.50	10
315	344.50	316.55	315.05	312.00	165.00	326.50	498.75	653.00	10
355	385.80	356.63	355.03	326.00	183.50	368.25	561.15	736.50	6
400	433.70	401.60	400.00	398.50	208.00	413.00	629.85	826.00	6

产品参数

尺寸 Size De	外形尺寸 Dimensions (mm)									
	D0	D1	D2	D3	d1	T1	T	L1	L2	L
110	125.70	111.50	110.20	96.00	108.00	125.00	122.00	160.80	282.00	455.00
160	181.50	162.30	160.30	140.00	158.00	145.00	141.00	194.00	371.20	575.00
200	225.00	202.50	200.20	178.00	197.00	160.00	152.00	215.80	426.50	660.00
250	276.50	252.30	250.30	227.00	247.00	180.00	152.00	232.50	508.70	739.00
315	347.80	318.30	315.20	288.00	312.00	202.00	198.00	284.00	636.80	917.00

REDUCING TEE

异三通

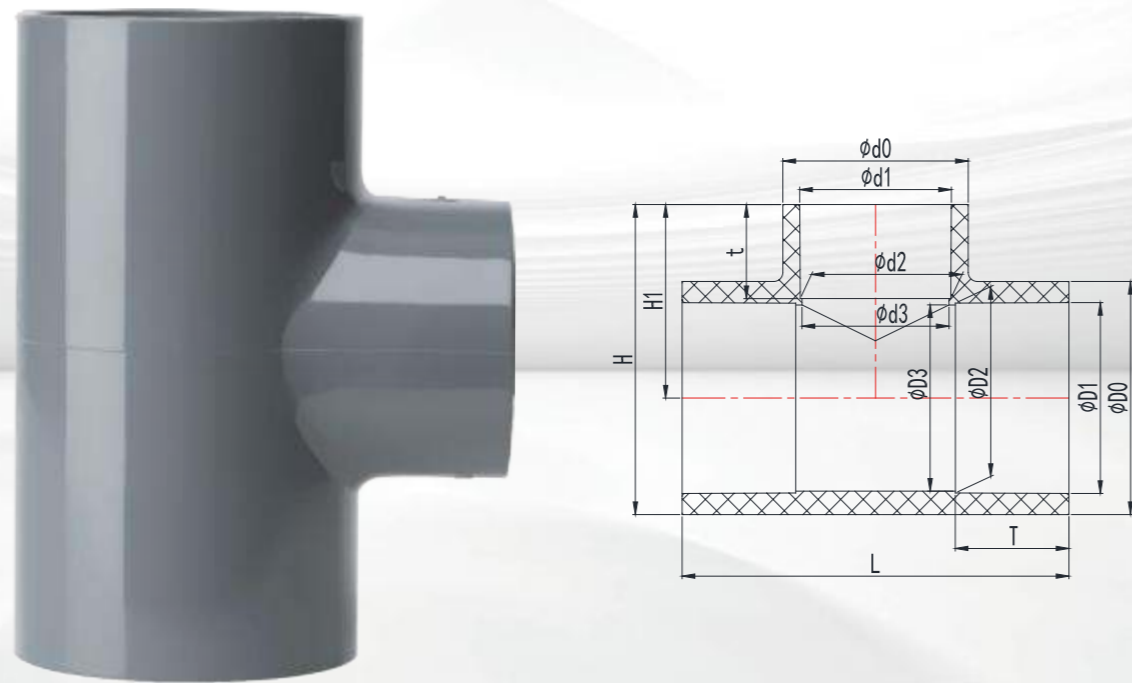

产品参数

尺寸 Size De	外形尺寸 Dimensions (mm)													公称压力 Nominal Pressure PN(kg/cm ²)
	D0	D1	D2	D3	d0	d1	d2	d3	t	T	H1	H	L	
25*20	30.02	25.24	24.95	24.00	24.18	20.24	19.96	19.00	17.00	19.50	31.00	46.01	62.10	10
32*20	37.44	32.25	31.95	31.00	24.74	20.24	19.96	19.00	17.00	23.00	34.50	53.22	69.20	10
32*25	37.44	32.25	31.95	31.00	30.10	25.24	24.95	24.00	19.50	23.00	37.00	55.72	73.80	10
40*20	46.30	40.28	39.95	39.00	25.40	20.24	19.96	19.00	17.00	27.00	38.50	61.65	77.30	10
40*25	46.30	40.28	39.95	39.00	30.05	25.24	24.95	24.00	19.50	27.00	41.00	64.15	80.40	10
40*32	46.30	40.28	39.95	39.00	37.44	32.25	31.95	29.00	23.00	27.00	44.50	67.65	89.00	10
50*20	57.20	50.33	49.94	49.00	25.00	20.24	19.96	19.00	17.00	32.00	43.50	72.10	86.00	10
50*25	57.72	50.33	49.94	49.00	30.05	25.24	24.95	24.00	19.50	32.00	46.00	74.86	92.00	10
50*32	57.80	50.33	49.94	49.00	37.50	32.25	31.95	31.00	23.00	32.00	49.50	78.40	98.70	10
50*40	57.10	50.33	49.94	49.00	47.02	40.28	39.95	39.00	27.00	32.00	53.50	82.05	108.40	10
63*20	70.00	63.34	62.93	62.00	24.90	20.24	19.96	19.00	17.00	38.50	50.00	85.00	100.00	10
63*25	70.10	63.34	62.93	62.00	30.20	25.24	24.95	24.00	19.50	38.50	52.50	87.55	105.00	10
63*32	70.80	63.34	62.93	62.00	37.50	32.25	31.95	31.00	23.00	38.50	56.00	91.40	112.00	10
63*40	70.30	63.34	62.93	62.00	45.80	40.28	39.95	39.00	27.00	38.50	60.00	95.15	119.85	10
63*50	70.80	63.34	62.93	62.00	56.50	50.33	49.94	49.00	32.00	38.50	65.00	100.40	130.60	10
75*32	84.30	75.35	74.93	73.50	38.20	32.25	31.95	31.00	23.00	44.50	61.75	103.90	125.75	10
75*40	84.10	75.35	74.93	73.50	46.60	40.28	39.95	39.00	27.00	44.50	65.75	107.80	135.70	10
75*50	84.00	75.35	74.93	73.50	57.00	50.33	49.94	49.00	32.00	44.50	70.75	112.75	153.50	10
75*63	83.80	75.35	74.93	73.50	70.70	63.34	62.93	62.00	38.50	44.50	77.25	119.15	156.60	10
90*50	100.70	90.38	89.93	88.50	56.70	50.33	49.94	49.00	32.00	52.00	78.25	128.60	158.00	10
90*63	100.70	90.38	89.93	88.50	69.70	63.34	62.93	62.00	38.50	52.00	84.75	135.10	170.30	10
90*75	100.70	90.38	89.93	88.50	84.10	75.35	74.93	73.50	44.50	52.00	90.75	141.10	183.00	10
110*50	123.00	110.42	109.92	108.00	56.30	50.33	49.94	49.00	32.00	62.00	88.00	149.50	177.00	10
110*63	122.70	110.42	109.92	108.00	74.00	63.34	62.93	62.00	38.50	62.00	94.50	155.85	190.10	10
110*75	121.32	110.42	109.92	108.00	84.30	75.35	74.95	73.50	44.50	62.00	101.50	162.16	201.50	10
110*90	121.50	110.42	109.92	108.00	100.60	90.38	89.93	88.50	52.00	62.00	109.00	169.75	220.40	10
125*75	136.50	125.52	124.93	123.00	84.30	75.35	74.95	73.50	44.50	69.50	109.00	177.25	219.50	10
125*90	137.80	125.52	124.93	123.00	99.20	90.38	89.93	88.50	52.00	69.50	116.50	185.40	232.30	10
125*110	136.00	125.52	124.93	123.00	120.60	110.42	109.92	108.00	62.00	69.50	125.75	193.75	250.70	10
140*110	151.50	140.58	139.88	138.00	108.70	110.42	109.92	108.00	62.00	77.00	134.00	209.75	268.00	10
160*90	175.30	160.62	159.87	158.00	101.60	90.38	89.93	88.50	52.00	87.00	134.00	221.65	268.00	10
160*110	175.40	160.62	159.87	158.00	122.30	110.42	109.92	108.00	62.00	87.00	144.00	231.70	288.00	10
160*125	175.30	160.62	159.87	158.00	137.00	125.30	124.93	123.00	69.50	87.00	151.50	239.15	300.00	10
160*140	175.10	160.62	159.87	158.00	153.00	140.30	139.88	138.00	77.00	87.00	159.00	246.55	318.50	10
180*160	202.60	180.81	179.91	178.50	180.00	160.35	159.87	158.00	87.00	97.00	180.00	281.30	379.00	10
200*75	220.90	180.81	199.85	197.00	82.75	75.35	74.93	73.50	44.50	107.00	148.50	258.95	291.50	10
200*90	220.90	200.90	199.85	197.00	99.20	90.38	89.93	88.50	52.00	107.00	156.00	266.45	307.00	10
200*110	219.20	200.90	199.85	197.00	122.80	110.42	109.92	108.00	62.00	107.00	166.00	275.60	328.00	10
200*160	219.80	200.90	199.85	197.00	175.40	160.62	159.87	158.00	87.00	107.00	191.00	300.90	377.00	10
225*160	246.00	226.02	224.83	221.00	175.00	160.62	159.87	158.00	87.00	119.50	203.00	326.00	407.00	10
250*110	272.00	251.15	249.41	247.00	120.50	110.42	109.92	108.00	62.00	132.00	191.00	327.00	377.00	10
250*160	270.00	251.15	249.41	247.00	173.00	160.62	159.87	158.00	87.00	132.00	216.00	351.00	427.00	10
250*200	274.10	251.15	249.41	247.00	220.00	200.90	199.85	197.00	107.00	132.00	236.00	373.05	474.00	10
280*250	314.80	281.46	280.16	278.00	280.00	251.15	199.85	247.00	132.00	147.00	276.00	433.40	580.00	10
315*110	344.50	316.55	315.05	312.00	125.75	110.42	109.92	108.00	62.00	165.00	223.50	395.75	448.00	10
315*160	344.50	316.55	315.05	312.00	178.60	160.62	159.87	158.00	87.00	165.00	248.50	420.75	498.00	10
315*200	344.50	316.55	315.05	312.00	220.90	200.90	199.85	197.00	107.00	165.00	268.50	440.75	538.00	10
315*250	344.50	316.55	315.05	312.00	273.40	251.15	225.83	247.00	132.00	165.00	293.50	465.75	588.00	10
355*200	386.50	356.63	355.03	326.00	219.90	200.90	199.85	197.00	107.00	183.50	285.50	478.75	590.50	6
355*225	386.50	356.80	355.00	326.00	259.40	226.20	224.90	216.90	184.00	118.70	298.50	491.60	615.00	6
355*250	386.50	356.63	355.03	326.00	273.40	251.15	249.41	247.00	132.00	183.50	311.50	504.75	638.50	6
355*315	386.50	356.63	355.03	326.00	344.50	316.55	315.05	312.00	165.00	183.50	350.60	543.85	694.50	6
400*200	432.70	401.60	400.00	398.50	220.90	200.90	199.85	197.00	107.00	208.00	318.60	534.95	623.00	6
400*250	432.40	401.60	400.00	398.50	273.50	251.15	249.41	247.00	132.00	208.00	342.80	559.00	672.00	6
400*315	432.70	401.60	400.00	398.50	344.50	316.55	315.05	312.00	165.00	208.00	370.00	586.35	752.00	6

LATERAL CROSS(F/F/S/S)

两承两插斜四通

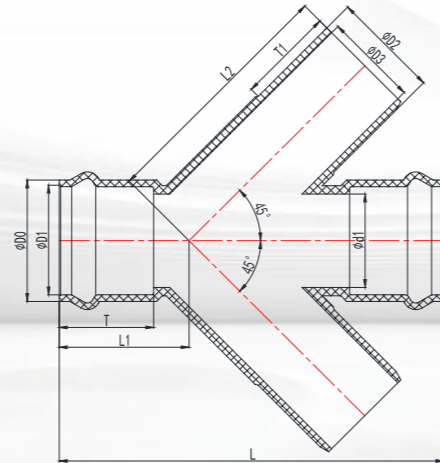

REDUCER(F/F)

双承异径

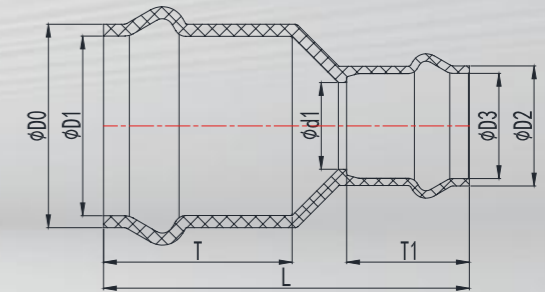

产品参数

尺寸 Size De	外形尺寸 Dimensions (mm)									
	D0	D1	D2	D3	d1	T1	T	L1	L2	L
110	125.70	111.50	110.20	96.00	108.00	125.00	122.00	160.80	282.00	455.00
160	181.50	162.30	160.30	140.00	158.00	145.00	141.00	194.00	371.20	575.00
200	225.00	202.50	200.20	178.00	197.00	160.00	152.00	215.80	426.50	660.00
250	276.50	252.30	250.30	227.00	247.00	180.00	152.00	232.50	508.70	739.00
315	347.80	318.30	315.20	288.00	312.00	202.00	198.00	284.00	636.80	917.00

产品参数

尺寸 Size De	外形尺寸 Dimensions (mm)							
	D0	D1	D2	D3	d1	T1	T	L
75*63	88.50	77.50	74.50	65.30	62.00	76.00	84.50	168.00
90*63	105.50	92.50	74.50	65.30	62.00	76.00	95.00	194.00
90*75	105.50	92.50	88.50	77.50	73.50	84.50	95.00	200.00
110*63	125.70	111.50	74.50	65.30	62.00	76.00	122.00	232.00
110*75	125.70	111.50	88.50	77.50	73.50	84.50	122.00	236.00
110*90	125.70	111.50	105.50	92.50	88.50	95.00	122.00	238.00
160*110	181.50	162.30	125.70	111.50	108.00	122.00	141.00	312.00
200*110	225.00	202.50	125.70	111.50	108.00	122.00	152.00	335.50
200*160	225.00	202.50	181.50	162.30	158.00	141.00	152.00	300.00
225*110	251.50	227.50	125.70	111.50	108.00	122.00	139.00	358.00
225*160	251.50	227.50	181.50	162.30	158.00	141.00	139.00	346.00
225*200	251.50	227.50	225.00	202.50	197.00	152.00	139.00	389.25
250*110	276.50	252.30	125.70	111.50	108.00	122.00	152.00	387.00
250*160	276.50	252.30	181.50	162.30	158.00	141.00	152.00	375.50
250*200	276.50	252.30	225.00	202.50	197.00	152.00	152.00	389.00
250*225	276.50	252.30	251.50	227.50	221.00	139.00	152.00	371.75
315*110	347.80	318.30	125.70	111.50	108.00	122.00	198.00	444.60
315*160	347.80	318.30	181.50	162.30	158.00	141.00	198.00	436.00
315*200	347.80	318.30	225.00	202.50	197.00	152.00	198.00	454.00
315*225	347.80	318.30	251.50	227.50	221.00	139.00	198.00	458.00
315*250	347.80	318.30	276.50	252.30	247.00	152.00	198.00	458.00
355*200	388.50	356.63	225.00	202.50	197.00	152.00	235.00	455.00
355*315	388.50	356.63	347.80	318.30	312.00	198.00	235.00	476.00

REDUCER

异径

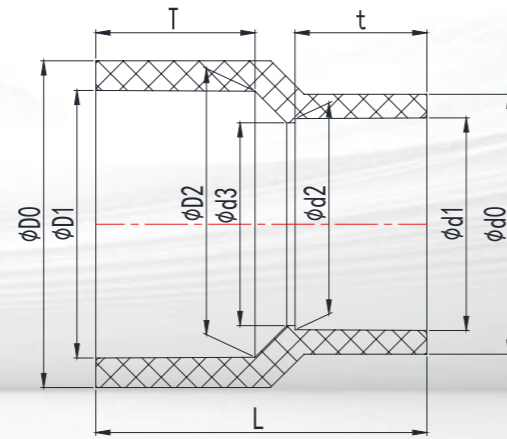

产品参数

尺寸 Size De	外形尺寸 Dimensions (mm)										公称压力 Nominal Pressure PN(kg/cm ²)
	D0	D1	D2	d0	d1	d2	d3	t	T	L	
25*20	30.05	25.24	24.95	24.85	20.24	19.96	19.00	17.00	19.50	41.80	10
32*20	37.40	32.25	31.95	24.85	20.24	19.96	19.00	17.00	23.00	48.50	10
32*25	37.40	32.25	31.95	30.00	25.24	24.95	24.00	19.50	23.00	48.50	10
40*20	46.70	40.28	39.95	26.10	20.24	19.96	19.00	17.00	27.00	55.10	10
40*25	46.70	40.28	39.95	31.30	25.24	24.95	24.00	19.50	27.00	55.50	10
40*32	46.80	40.28	39.95	38.70	32.25	31.95	31.00	23.00	27.00	55.20	10
50*20	56.60	50.33	49.94	24.85	20.24	19.96	19.00	17.00	32.00	66.50	10

产品参数

50*25	56.80	50.33	49.94	30.00	32.25	31.95	24.00	23.00	32.00	66.50	10
50*32	56.60	50.33	49.94	37.50	40.28	39.95	31.00	27.00	32.00	66.50	10
50*40	57.20	50.33	49.94	47.10	40.28	39.95	39.00	27.00	32.00	66.20	10
63*25	71.70	63.34	62.93	31.20	25.24	24.95	24.00	19.50	38.50	79.50	10
63*32	72.10	63.34	62.93	38.30	32.25	31.95	31.00	23.00	38.50	79.50	10
63*40	71.50	63.34	62.93	47.00	40.28	39.95	39.00	27.00	38.50	78.80	10
63*50	83.30	63.34	62.93	57.40	50.33	49.94	49.00	32.00	38.50	80.00	10
75*32	83.30	75.35	74.93	38.00	32.25	31.95	31.00	23.00	44.50	92.50	10
75*40	83.30	75.35	74.93	46.20	40.28	39.95	39.00	27.00	44.50	92.50	10
75*50	83.30	75.35	74.93	56.50	50.33	49.94	49.00	32.00	44.50	92.30	10
75*63	83.30	75.35	74.93	70.30	63.34	62.93	62.00	38.50	44.50	91.80	10
90*40	99.20	90.38	89.93	46.00	40.28	39.95	39.00	27.00	52.00	106.50	10
90*50	99.20	90.38	89.93	56.30	50.33	49.94	49.00	32.00	52.00	107.50	10
90*63	99.20	90.38	89.93	71.00	63.34	62.93	62.00	38.50	52.00	109.00	10
90*75	99.20	90.38	89.93	84.00	75.35	74.93	73.50	44.50	52.00	107.50	10
110*50	120.80	110.42	109.92	56.70	50.33	49.94	49.00	32.00	62.00	125.75	10
110*63	120.80	110.42	109.92	70.55	63.34	62.93	62.00	38.50	62.00	125.00	10
110*75	120.80	110.42	109.92	84.20	75.35	74.93	73.50	44.50	62.00	128.60	10
110*90	120.80	110.42	109.92	100.30	90.38	89.93	88.50	52.00	62.00	125.78	10
125*63	135.20	125.52	124.93	69.50	63.34	62.93	62.00	38.50	69.50	142.50	10
125*75	135.20	125.52	124.93	82.70	75.35	74.93	73.50	44.50	69.50	142.50	10
125*90	137.30	125.52	124.93	99.50	90.38	89.93	88.50	52.00	69.50	142.50	10
125*110	137.00	125.52	124.93	121.60	110.42	109.92	108.00	62.00	69.50	142.50	10
140*90	151.50	140.58	139.88	99.30	90.38	89.93	88.50	52.00	77.00	151.50	10
140*110	152.60	140.58	139.88	119.60	110.42	109.92	108.00	62.00	77.00	157.00	10
160*90	175.30	160.62	159.87	99.50	90.38	89.93	88.50	52.00	87.00	175.30	10
160*110	175.10	160.62	159.87	121.60	110.42	109.92	108.00	62.00	87.00	178.00	10
160*125	175.60	160.62	159.87	137.20	125.52	124.93	123.00	69.50	87.00	119.00	10
160*140	175.10	160.62	159.87	152.80	140.58	139.88	138.00	77.00	87.00	178.00	10
180*160	202.80	180.81	179.91	180.00	160.62	159.87	158.00	87.00	97.00	202.50	10
200*110	217.90	200.90	199.85	122.60	110.42	109.92	108.00	62.00	107.00	218.50	10
200*125	217.40	200.90	199.85	136.70	125.52	124.93	123.00	69.50	107.00	219.00	10
200*140	218.50	200.90	199.85	153.10	140.58	139.88	138.00	77.00	107.00	221.00	10
200*160	218.50	200.90	199.85	175.00	160.62	159.87	158.00	87.00	107.00	221.00	10
225*110	245.80	226.02	224.83	121.80	110.42	109.92	108.00	62.00	119.50	245.00	10
225*125	245.50	226.02	224.83	136.60	125.52	124.93	123.00	69.50	119.50	245.00	10
225*160	245.80	226.02	224.83	174.86	160.62	159.87	158.00	87.00	119.50	245.00	10
225*200	245.80	226.02	224.83	218.50	200.90	199.85	197.00	107.00	119.50	245.00	10
250*110	272.20	251.15	249.41	121.80	110.42	109.92	108.00	62.00	132.00	265.00	10
250*160	269.30	251.15	249.41	174.90	160.62	159.87	158.00	87.00	132.00	272.00	10
250*200	270.00	251.15	249.41	217.20	200.90	199.85	197.00	107.00	132.00	272.00	10
280*250	315.50	281.46	280.16	280.40	251.15	249.41	247.00	132.00	147.00	304.00	10
315*110	343.30	316.55	315.05	125.75	110.42	109.92	108.00	62.00	165.00	380.60	10
315*125	343.50	316.55	315.05	142.40	125.52	124.93	123.00	69.50	165.00	377.80	10
315*160	343.00	316.55	315.05	178.60	160.62	159.87	158.00	87.00	165.00	371.00	10
315*200	343.00	316.55	315.05	220.90	200.90	199.85	197.00	107.00	165.00	358.00	10
315*225	342.80	316.55	315.05	246.70	226.02	224.83	221.00	119.50	165.00	354.50	10
315*250	342.80	316.55	315.05	273.70	251.15	249.41	247.00	132.00	165.00	351.00	10
355*200	386.10	356.63	355.03	220.90	200.90	199.85	197.00	107.00	183.50	400.00	6
355*250	386.10	356.63	355.03	273.70	251.15	249.41	247.00	132.00	183.50	392.60	6
355*315	386.10	356.63	355.03	344.00	316.55	315.05	312.00	165.00	183.50	384.00	6
400*200	432.70	401.60	400.00	220.90	200.90	199.85	197.00	107.00	208.00	453.50	6
400*250	431.30	401.60	400.00	273.70	251.15	249.41	247.00	132.00	208.00	447.00	6
400*315	432.70	401.60	400.00	344.30	316.55	315.05	312.00	165.00	208.00	438.50	6
400*355	432.30	401.60	400.00	386.40	356.63	355.03	326.00	183.50	208.00	430.80	6

COPPER THREADED CAP

铜内螺纹管堵

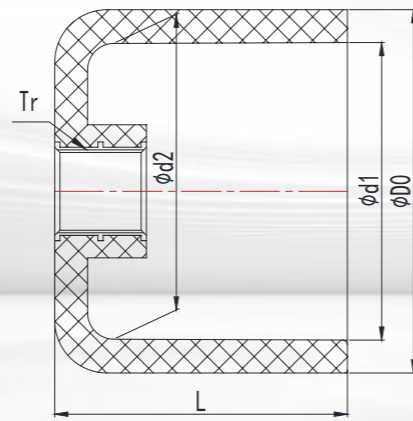

CAP

管堵

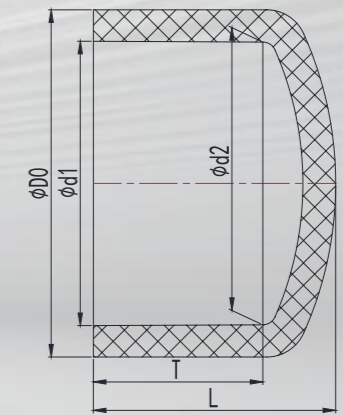

产品参数

尺寸 Size De	外形尺寸 Dimensions (mm)					公称压力 Nominal Pressure PN(kg/cm ²)
	D0	d1	d2	L	Tr 螺纹	
63*3/4"	70.50	63.34	62.93	56.00	3/4"	10
63*1"	70.50	63.34	62.93	56.00	1"	10

产品参数

尺寸 Size De	外形尺寸 Dimensions (mm)					公称压力 Nominal Pressure PN(kg/cm ²)
	D0	d1	d2	T	L	
20	24.50	20.24	19.96	17.00	21.20	10
25	29.80	25.24	24.95	19.50	24.80	10
32	37.10	32.25	31.95	23.00	30.00	10
40	45.80	40.28	39.95	27.00	35.00	10
50	56.70	50.33	49.94	32.00	42.00	10
63	70.30	63.34	62.93	38.50	50.40	10
75	83.30	75.35	74.93	44.50	58.50	10
90	100.10	90.38	89.93	52.00	68.30	10
110	119.80	110.42	109.92	62.00	80.00	10
125	136.38	125.52	124.93	69.50	91.00	10
140	151.00	140.58	139.88	77.00	101.00	10
160	173.50	160.62	159.87	87.00	116.00	10
180	202.60	180.81	179.91	97.00	143.00	10
200	220.00	200.90	199.85	107.00	150.00	10
225	243.30	226.02	224.83	119.50	156.00	10
250	273.70	251.15	249.41	132.00	185.00	10
280	315.00	281.46	280.16	147.00	213.00	10
315	343.50	316.55	315.05	165.00	216.00	10
355	384.60	356.63	355.03	183.50	255.50	6
400	430.70	401.60	400.00	208.00	295.00	6

COUPLING(F/F)

双承管箍

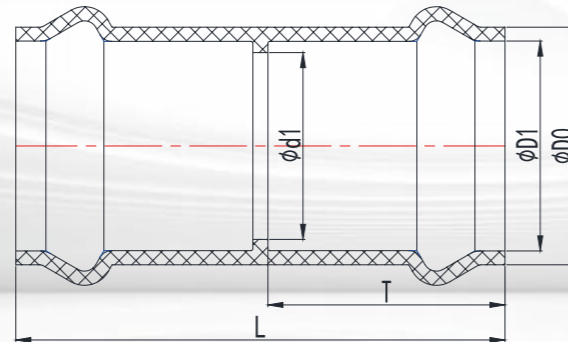

COPPER THREADED REDUCER

铜内丝直接

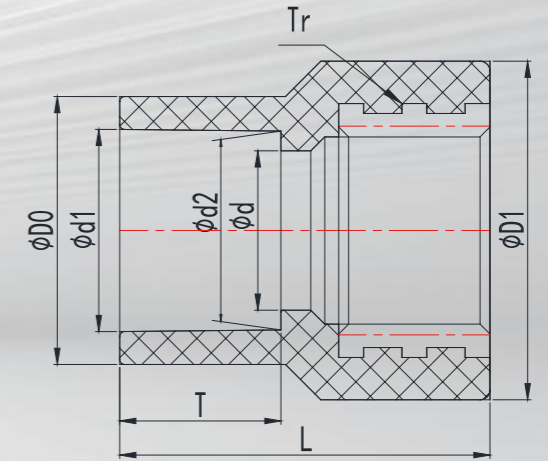

产品参数

尺寸 Size De	外形尺寸 Dimensions (mm)				
	D0	D1	d1	T	L
63	74.50	65.30	62.00	76.00	158.00
75	88.50	77.50	73.50	84.50	177.50
90	105.50	92.50	88.50	95.00	200.00
110	125.70	111.50	108.00	122.00	280.00
160	181.50	162.30	158.00	141.00	303.00
200	225.00	202.50	197.00	152.00	310.00
225	251.50	227.50	221.00	139.00	362.00
250	276.50	252.30	247.00	152.00	382.70
315	347.80	318.30	312.00	198.00	484.00
355	388.50	356.63	326.00	235.00	384.30

产品参数

尺寸 Size De	外形尺寸 Dimensions (mm)								公称压力 Nominal Pressure PN(kg/cm ²)
	D0	D1	d1	d2	d	T	L	Tr 螺纹	
20*1/2"	24.30	32.00	20.24	19.96	18.00	17.00	36.70	1/2"	10
25*1/2"	31.00	33.00	25.24	24.95	18.80	19.50	39.20	1/2"	10
25*3/4"	29.80	38.10	25.24	24.95	18.80	19.50	39.50	3/4"	10
32*1/2"	37.30	32.00	32.25	31.95	18.80	23.00	48.50	1/2"	10
32*3/4"	37.50	37.50	32.25	31.95	24.00	23.00	48.50	3/4"	10
32*1"	38.00	46.40	32.25	31.95	31.00	23.00	42.40	1"	10

COUPLING

管箍

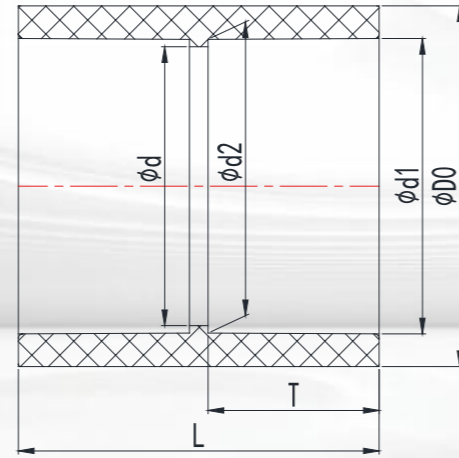

BRACKET

管卡

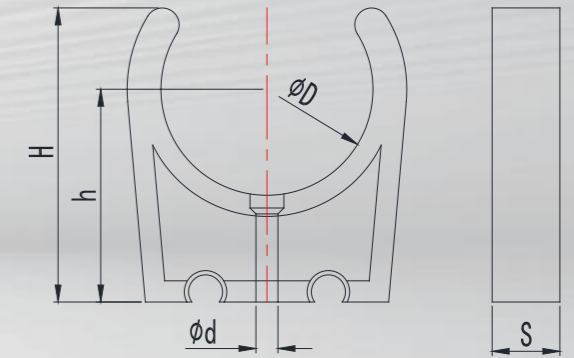

产品参数

尺寸 Size De	外形尺寸 Dimensions (mm)						公称压力 Nominal Pressure PN(kg/cm ²)
	D0	d1	d2	d	T	L	
20	24.80	20.24	19.96	19.00	17.00	36.00	10
25	29.90	25.24	24.95	24.00	19.50	41.30	10
32	37.40	32.25	31.95	31.00	23.00	48.10	10
40	47.00	40.28	39.95	39.00	27.00	56.60	10
50	56.50	50.33	49.94	49.00	32.00	67.00	10
63	70.50	63.34	62.93	62.00	38.50	81.00	10
75	83.30	75.35	74.93	73.50	44.50	93.00	10
90	100.00	90.38	89.93	88.50	52.00	107.60	10
110	119.84	110.42	109.92	108.00	62.00	128.30	10
125	136.30	125.52	124.93	123.00	69.50	147.20	10
140	153.50	140.58	139.88	138.00	77.00	163.60	10
160	174.70	160.62	159.87	158.00	87.00	183.30	10
180	202.50	180.81	179.91	178.50	97.00	203.50	10
200	218.90	200.90	199.85	197.00	107.00	217.00	10
225	245.80	226.02	224.83	221.00	119.50	245.00	10
250	269.80	251.15	249.41	247.00	132.00	279.00	10
280	314.80	281.46	280.16	278.00	147.00	299.50	10
315	343.70	316.55	315.05	312.00	165.00	343.00	10
355	384.60	356.63	355.03	326.00	183.50	373.00	6
400	430.70	401.60	400.00	398.50	208.00	423.00	6

产品参数

尺寸 Size De	外形尺寸 Dimensions (mm)				
	D	d	S	h	H
20	20.00	4.50	12.60	29.80	38.20
25	25.00	4.50	16.10	32.40	40.00
32	32.00	4.50	19.10	35.70	46.00
40	40.00	6.00	22.00	44.00	53.00
50	50.00	6.00	24.00	51.00	60.00
63	63.00	6.00	26.00	60.50	69.00

UNION

由任 (由令)

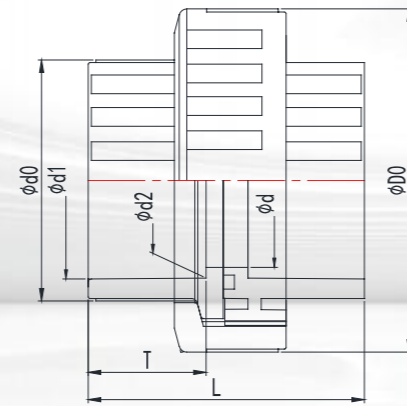
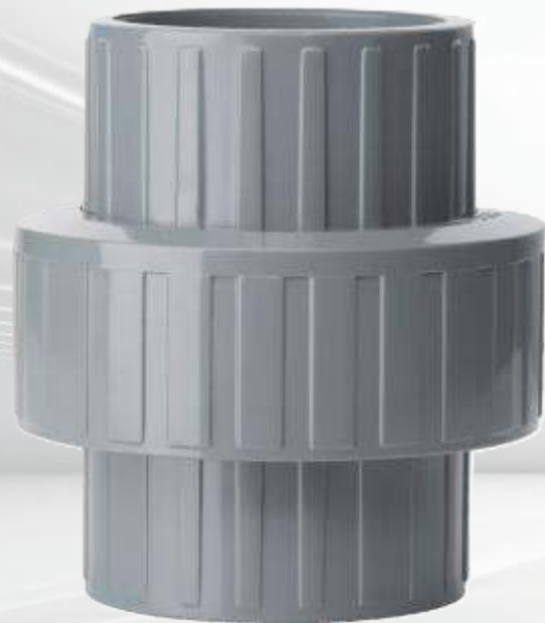

BUSHING

变径 (补芯)

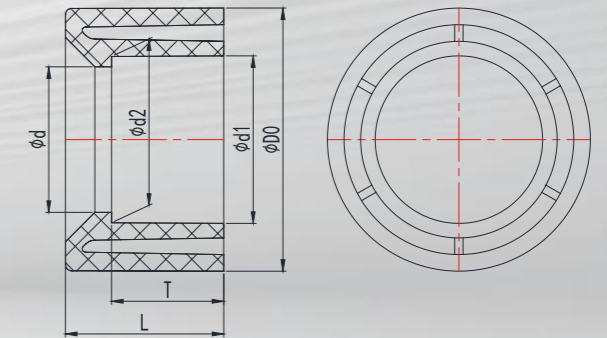

产品参数

尺寸 Size De	外形尺寸 Dimensions (mm)							公称压力 Nominal Pressure PN(kg/cm ²)
	D0	d0	d1	d2	d	T	L	
20	45.50	26.00	20.24	19.96	19.00	17.00	53.00	10
25	54.50	32.00	25.24	24.95	24.00	19.50	59.80	10
32	65.00	39.50	32.25	31.95	31.00	23.00	68.50	10
40	75.50	48.50	40.28	39.95	39.00	27.00	80.50	10
50	88.50	59.00	50.33	49.94	49.00	32.00	94.00	10
63	102.00	74.50	63.34	62.93	62.00	38.50	110.00	10
75	122.60	86.00	75.35	74.93	73.50	44.50	104.70	10
90	140.70	101.20	90.38	89.93	88.50	52.00	121.10	10
110	163.60	122.20	110.42	109.92	108.00	62.00	147.00	10

产品参数

尺寸 Size De	外形尺寸 Dimensions (mm)							公称压力 Nominal Pressure PN(kg/cm ²)
	D0	d1	d2	d	T	L		
25*20	25.10	20.24	19.96	19.00	17.00	19.00	10	
32*25	32.20	25.24	24.95	24.00	19.50	22.20	10	
40*32	40.10	32.25	31.95	31.00	23.00	26.50	10	
50*40	50.06	40.28	39.95	39.00	27.00	30.60	10	
63*50	63.10	50.33	49.94	49.00	32.00	38.00	10	
75*63	75.10	63.34	62.93	62.00	38.50	44.00	10	
90*75	90.10	75.35	74.93	73.00	44.50	51.00	10	
110*90	110.10	90.38	89.93	88.50	52.00	60.50	10	
125*110	125.10	110.42	109.92	108.00	62.00	68.50	10	
140*110	140.10	110.42	109.92	108.00	62.00	76.70	10	
140*125	140.10	125.52	124.93	123.00	69.50	76.70	10	
160*110	160.10	110.42	109.92	108.00	62.00	86.00	10	
160*140	160.10	140.58	139.88	138.00	77.00	86.00	10	
180*160	180.10	160.62	159.87	158.00	87.00	96.00	10	
200*160	200.10	160.62	159.87	158.00	87.00	106.00	10	
200*180	200.10	180.81	179.91	178.50	97.00	106.00	10	
225*160	225.20	160.62	159.87	158.00	87.00	119.80	10	
225*200	225.20	200.90	199.85	197.00	107.00	118.00	10	
250*200	250.20	200.90	199.85	197.00	107.00	128.40	10	
250*225	250.20	226.02	224.83	221.00	119.50	128.40	10	
280*225	280.10	226.02	224.83	221.00	119.50	145.50	10	
315*280	315.10	281.46	280.16	278.00	147.00	164.00	10	
355*315	355.10	316.55	315.05	312.00	165.00	184.00	6	
400*315	400.10	316.55	315.05	312.00	165.00	216.00	6	

FEMALE ADAPTOR

内丝

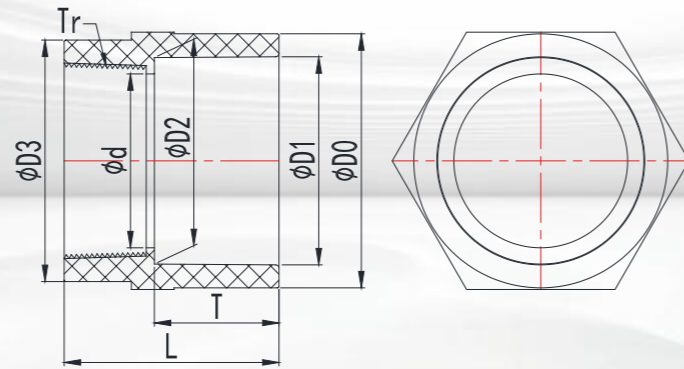

MALE ADAPTOR

外丝

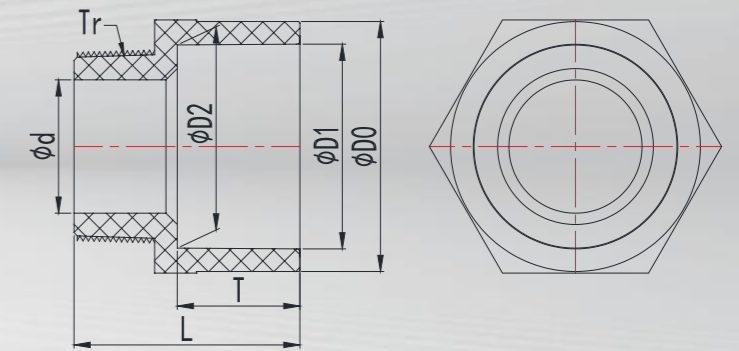

产品参数

尺寸 Size De	外形尺寸 Dimensions (mm)								公称压力 Nominal Pressure PN(kg/cm ²)
	D0	D1	D2	D3	d	T	L	Tr 螺纹	
20*1/2"	26.50	20.24	19.96	28.00	19.00	17.00	36.50	1/2"	10
25*3/4"	30.50	25.24	24.95	32.00	24.00	19.50	37.00	3/4"	10
32*1"	37.40	32.25	31.95	38.00	31.00	23.00	43.00	1"	10
40*1-1/4"	46.20	40.28	39.95	47.60	39.00	27.00	50.00	1-1/4"	10
50*1-1/2"	56.60	50.33	49.94	54.00	49.00	32.00	54.00	1-1/2"	10
63*2"	70.50	63.34	62.93	57.00	62.00	38.50	64.30	2"	10
75*2-1/2"	84.00	75.35	74.93	84.00	73.50	44.50	76.60	2-1/2"	10
90*3"	100.60	90.38	89.93	100.00	88.50	52.00	93.40	3"	10
110*4"	121.40	110.42	109.92	125.30	108.00	62.00	105.50	4"	10

产品参数

尺寸 Size De	外形尺寸 Dimensions (mm)								公称压力 Nominal Pressure PN(kg/cm ²)
	D0	D1	D2	d	T	L	Tr 螺纹		
20*1/2"	26.00	20.24	19.96	17.00	17.00	38.50	1/2"	10	
25*3/4"	30.40	25.24	24.95	17.80	19.50	40.50	3/4"	10	
32*1"	37.50	32.25	31.95	23.00	23.00	47.50	1"	10	
40*1-1/4"	46.20	40.28	39.95	30.30	27.00	54.50	1-1/4"	10	
50*1-1/2"	56.80	50.33	49.94	37.60	32.00	63.10	1-1/2"	10	
63*2"	70.60	63.34	62.93	47.50	38.50	76.50	2"	10	
75*2-1/2"	83.60	75.35	74.93	60.00	44.50	87.50	2-1/2"	10	
90*3"	100.70	90.38	89.93	72.00	52.00	94.00	3"	10	
110*4"	121.40	110.42	109.92	95.00	62.00	119.50	4"	10	

MALE ADAPTOR(T/T)

双头外丝



FAUCET FLANGE

承口法兰

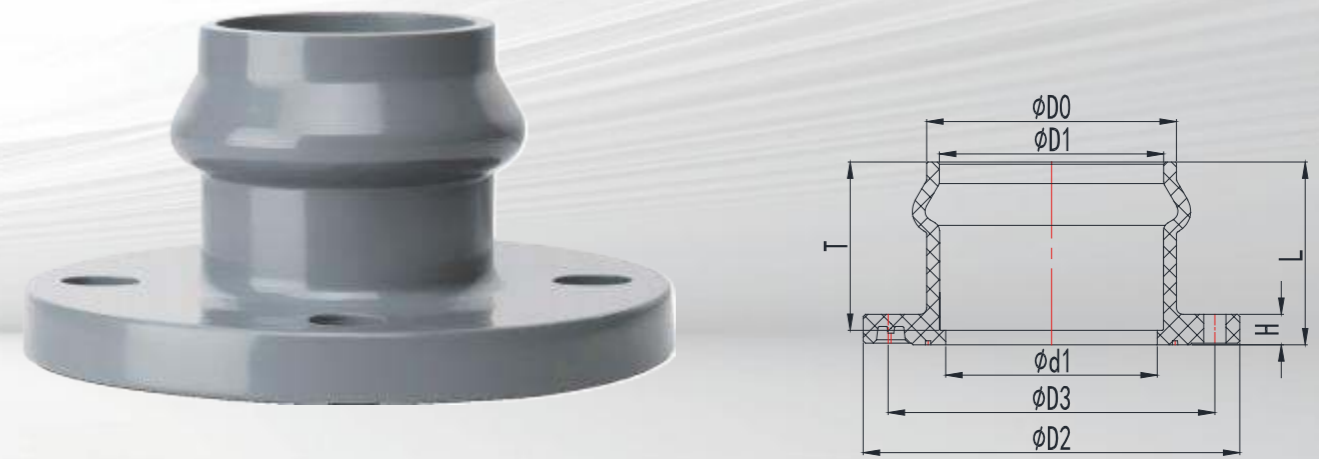

产品参数

尺寸 Size De	外形尺寸 Dimensions (mm)					公称压力 Nominal Pressure PN(kg/cm ²)
	D0	d	L1	L	Tr 螺纹	
20*1/2"	20.80	14.50	7.00	40.50	1/2"	10
25*3/4"	25.70	17.50	8.00	45.00	3/4"	10
32*1"	33.10	24.00	11.00	50.00	1"	10
40*1-1/4"	41.40	32.00	11.00	52.50	1-1/4"	10
50*1-1/2"	47.30	37.50	12.50	55.00	1-1/2"	10
63*2"	58.60	48.50	12.50	67.00	2"	10

产品参数

尺寸 Size De	外形尺寸 Dimensions (mm)								
	D0	D1	D2	D3	d1	T	H	L	螺孔数 n
63	74.50	65.30	165.00	125.00	62.00	76.00	17.30	84.00	4
75	88.50	77.50	185.00	145.00	73.50	84.50	18.00	92.30	4
90	105.30	92.50	200.00	160.00	88.50	95.00	18.80	103.00	8
110	125.70	111.50	225.00	180.00	108.00	122.00	19.50	134.00	8
125	142.10	127.00	250.00	210.00	123.00	135.00	21.60	135.00	8
140	160.10	143.00	251.80	210.00	125.90	141.30	20.30	151.40	8
160	181.50	162.30	285.00	240.00	158.00	141.00	22.80	150.00	8
180	200.00	182.00	290.00	240.00	161.00	150.30	25.00	160.80	8
200	225.50	202.50	345.00	295.00	197.00	152.00	26.50	163.00	8
225	250.50	227.50	345.00	295.00	221.00	139.00	30.00	153.50	8
250	276.50	252.30	395.00	350.00	247.00	152.00	32.00	167.50	12
280	309.50	282.50	405.00	355.00	254.00	173.60	31.50	193.30	12
315	347.50	318.30	445.00	400.00	312.00	198.00	35.00	210.00	12
355	388.50	359.00	510.00	460.00	326.00	235.00	38.00	210.00	16
400	435.00	404.00	570.00	515.00	568.20	228.00	42.50	247.00	16

SPIGOT FLANGE

插口法兰

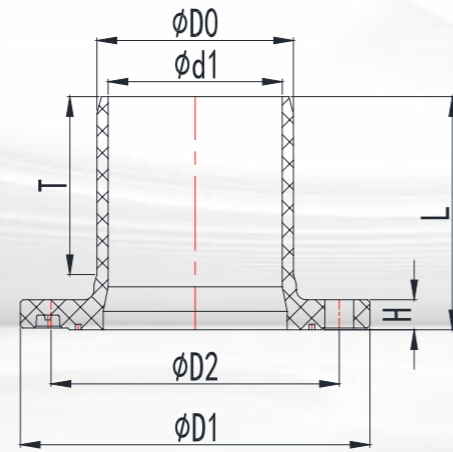

ONE-PIECE FLANGE

单片式法兰

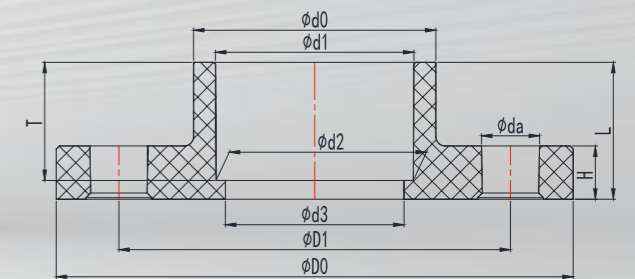

产品参数

尺寸 Size De	外形尺寸 Dimensions (mm)								公称压力 Nominal Pressure PN(kg/cm ²)
	D0	D1	D2	d1	T	H	L	螺孔数 n	
63	63.20	164.00	125.00	62.00	102.00	17.30	127.00	4	10
75	75.30	184.00	145.00	73.50	110.00	17.00	137.50	4	10
90	90.30	198.50	160.00	88.50	115.00	19.00	144.00	8	10
110	110.30	223.50	180.00	108.00	128.00	20.00	154.00	8	10
160	160.40	283.50	240.00	123.00	145.00	23.00	190.00	8	10
200	200.50	338.00	295.00	158.00	160.00	27.00	203.50	8	10
225	225.50	345.00	295.00	197.00	167.00	29.50	216.00	8	10
250	250.50	393.00	350.00	221.00	180.00	31.00	232.00	12	10
315	315.60	443.50	400.00	312.00	207.00	35.50	268.00	12	10
355	355.60	510.00	460.00	326.00	235.00	42.50	300.00	16	10
400	400.60	568.20	510.00	568.20	245.00	41.00	314.00	16	10

产品参数

尺寸 Size De	外形尺寸 Dimensions (mm)											公称压力 Nominal Pressure PN(kg/cm ²)
	D0	D1	d0	d1	d2	d3	da	T	H	L	螺孔数 n	
20	94.00	65.00	28.30	20.24	19.96	19.00	14.00	17.00	14.50	24.50	4	10
25	104.00	75.00	33.20	25.24	24.95	24.00	14.00	19.50	14.50	24.80	4	10
32	114.10	85.00	41.60	32.25	31.95	31.00	14.00	23.00	13.50	23.30	4	10
40	133.50	100.00	49.60	40.28	39.95	39.00	18.00	27.00	17.20	36.00	4	10
50	148.00	110.00	57.40	50.33	49.94	49.00	18.00	32.00	15.70	46.50	4	10
63	164.00	125.00	71.40	63.34	62.93	62.00	18.00	38.50	17.00	48.50	4	10
75	183.40	145.00	86.80	75.35	74.93	73.00	18.00	44.50	19.30	61.50	4	10
90	198.50	160.00	101.30	90.38	89.93	88.50	18.00	52.00	19.50	70.00	8	10
110	218.20	180.00	123.20	110.42	109.92	108.00	18.00	62.00	19.10	80.00	8	10
140	249.00	210.00	152.80	140.58	139.88	138.00	18.00	77.00	20.00	87.00	8	10
160	283.50	240.00	176.20	160.62	159.87	158.00	22.00	87.00	22.00	105.00	8	10
180	284.00	240.00	202.60	180.81	179.91	178.50	22.00	97.00	25.30	114.00	8	10
200	340.50	295.00	219.40	200.90	199.85	197.00	22.00	107.00	25.50	128.50	8	10
250	394.00	350.00	272.50	251.15	249.41	247.00	22.00	132.00	31.00	156.00	12	10
280	403.00	355.00	303.90	281.46	280.16	278.00	22.00	147.00	29.70	167.00	12	10

VANSTONE FLANGE

双片式法兰 (活套)

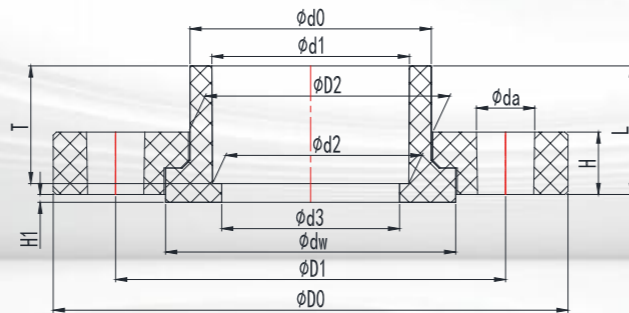

COPPER THREADED BLIND FLANGE

丝口盲法兰

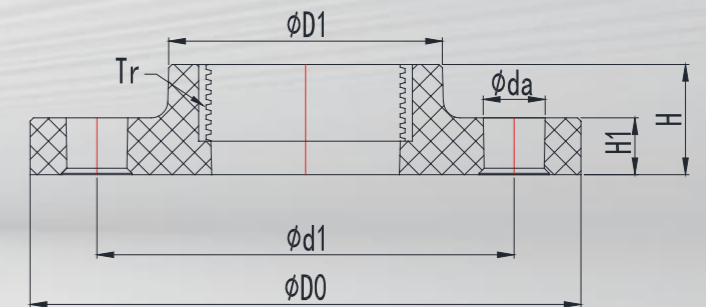

产品参数

尺寸 Size De	外形尺寸 Dimensions (mm)														公称压力 Nominal Pressure PN(kg/cm ²)
	D0	D1	D2	d0	d1	d2	d3	dw	da	T	H1	H	L	螺孔数 n	
50	148.00	110.00	60.10	56.60	50.33	49.94	49.00	82.00	18.00	32.00	7.60	14.50	35.00	4	10
63	165.60	125.00	75.20	69.60	63.34	62.93	62.00	93.70	18.00	38.50	8.00	15.60	42.30	4	10
75	185.00	145.00	87.00	82.60	75.35	74.93	73.00	103.80	18.00	44.50	8.30	16.10	47.80	4	10
90	194.90	160.00	105.00	99.30	90.38	89.93	88.50	128.40	18.00	52.00	10.50	18.20	54.50	8	10
110	219.00	180.00	132.00	120.30	110.42	109.92	108.00	150.00	18.00	62.00	14.50	20.00	66.10	8	10
125	248.00	210.00	145.00	136.60	125.52	124.93	123.00	163.80	18.00	69.50	15.50	19.30	74.10	8	10
140	248.50	210.00	152.50	151.60	140.58	139.88	138.00	167.80	18.00	77.00	12.50	21.00	83.00	8	10
160	284.00	240.00	186.50	177.60	160.62	159.87	158.00	260.50	22.00	87.00	19.50	26.00	91.20	8	10
200	340.00	295.00	230.50	220.50	200.90	199.85	197.00	258.50	22.00	107.00	20.00	29.80	113.00	8	10
225	340.00	295.00	253.00	245.50	226.02	224.83	221.00	266.70	22.00	119.50	21.50	32.00	123.00	8	10
250	393.00	350.00	277.00	275.00	251.15	249.41	247.00	303.00	22.00	132.00	22.50	34.00	138.00	12	10
280	397.00	355.00	308.00	305.40	281.46	280.16	278.00	324.50	22.00	147.00	22.00	35.00	162.00	12	10
315	445.00	400.00	353.50	346.30	316.55	315.05	312.00	378.50	22.00	165.00	30.00	40.00	157.70	12	10
355	510.00	460.00	390.00	386.60	356.63	355.03	326.00	413.50	24.00	183.50	32.00	40.00	193.50	16	10
400	570.00	515.00	438.00	432.00	401.60	400.00	398.50	460.00	24.00	208.00	40.00	43.80	200.00	16	10
450	620.00	565.00	488.50	486.00	451.94	450.05	447.00	518.00	27.00	233.00	38.00	45.00	245.00	20	10
500	670.00	620.00	541.00	536.50	502.80	500.60	596.00	573.00	27.00	256.00	38.00	50.00	268.00	20	10

产品参数

尺寸 Size De	外形尺寸 Dimensions (mm)								公称压力 Nominal Pressure PN(kg/cm ²)
	D0	D1	d1	da	H1	H	螺孔数 n	Tr 螺纹	
110*2"	219.00	82.00	180.00	18.00	21.50	39.50	8	2"	10
160*2"	283.00	82.00	240.00	22.00	25.00	38.00	8	2"	10
200*2"	340.00	84.00	295.00	22.00	30.00	48.00	8	2"	10

BLIND FLANGE

盲法兰

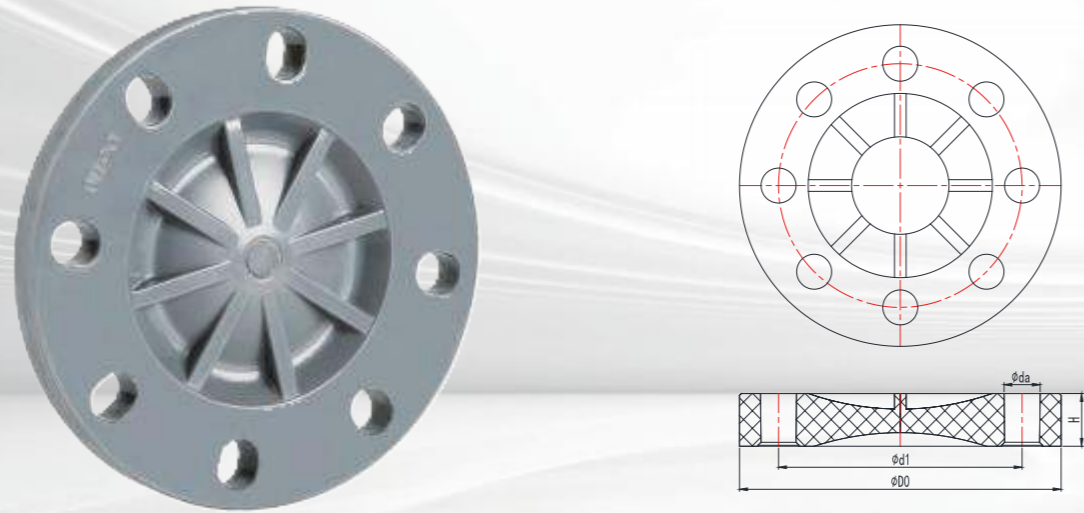

COMPRESSION COUPLING

抢修节 (普通式)

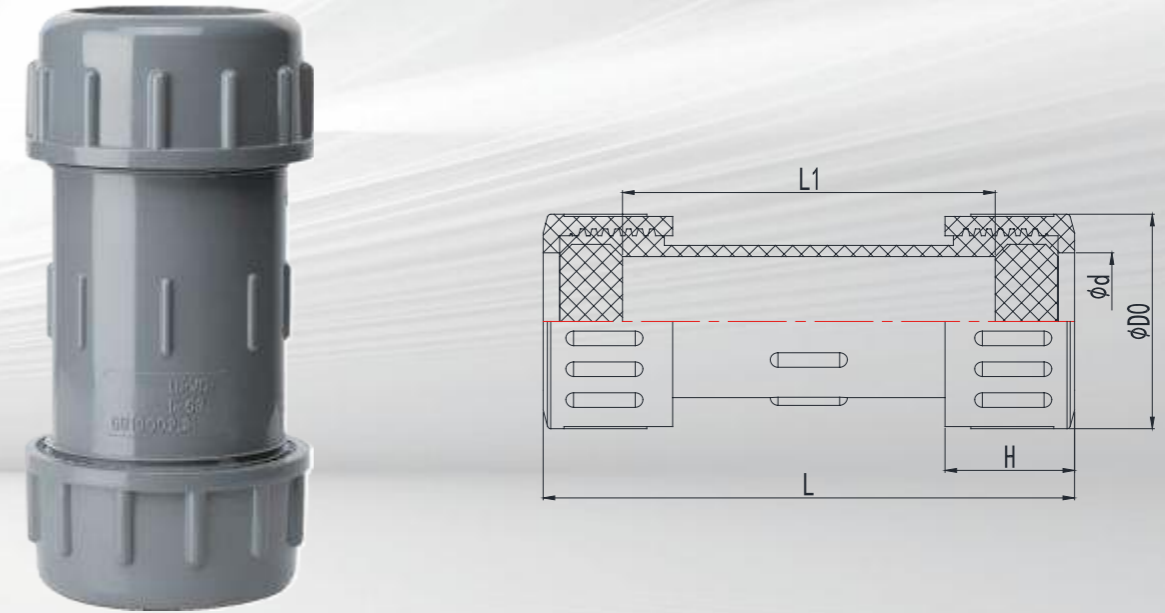

产品参数

尺寸 Size De	外形尺寸 Dimensions (mm)					公称压力 Nominal Pressure PN(kg/cm ²)
	D0	d1	da	H	螺孔数 n	
20	95.00	65.00	14.00	12.50	4	10
25	105.00	75.00	14.00	13.40	4	10
32	115.00	85.00	14.00	14.00	4	10
40	140.00	100.00	18.00	14.40	4	10
50	150.00	110.00	18.00	16.40	4	10
63	165.00	125.00	18.00	16.20	4	10
75	185.00	145.00	18.00	17.50	4	10
90	200.00	160.00	18.00	18.00	8	10
110	219.00	180.00	18.00	21.50	8	10
160	283.00	240.00	22.00	25.00	8	10
200	340.00	295.00	22.00	30.00	8	10
250	405.00	350.00	22.00	29.00	12	10
315	445.00	400.00	22.00	31.50	12	10
355	510.00	450.00	24.00	40.00	16	10
400	570.00	500.00	27.00	42.00	16	10

产品参数

尺寸 Size De	外形尺寸 Dimensions (mm)				
	D0	d	H	L1	L
20	44.50	20.60	30.00	100.00	123.00
25	49.00	25.50	31.00	111.50	131.00
32	57.50	33.00	34.50	115.00	140.00
40	72.30	40.60	37.00	120.00	148.00
50	77.00	51.00	40.00	132.00	165.00
63	91.60	69.00	47.00	153.00	190.00
75	105.50	76.00	47.00	183.00	210.00
90	132.00	92.00	55.00	210.00	258.00
110	158.00	112.50	62.00	230.00	290.00
125	183.00	125.75	52.00	184.50	290.00
160	219.00	161.00	59.00	248.50	283.00

SADDLED REPAIRED COUPLING

多功能抢修节 (哈夫式)

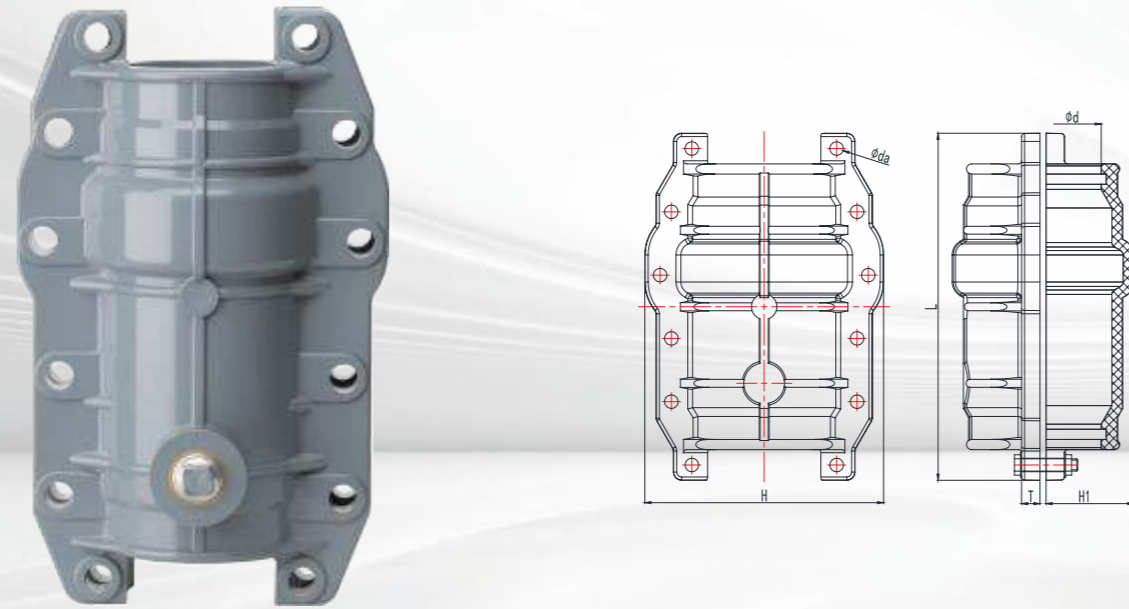

REPAIRED COUPLING

抢修节 (活套式)

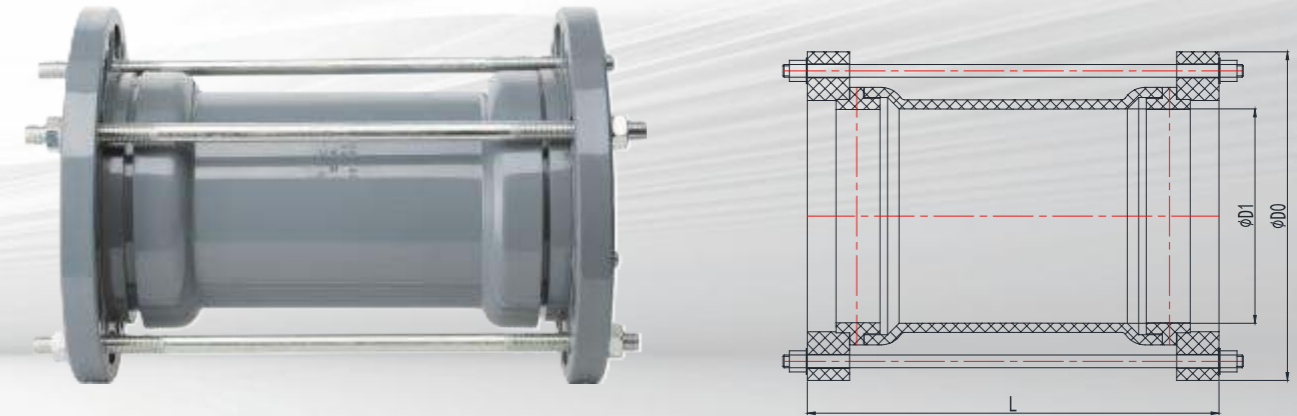

产品参数

尺寸 Size De	外形尺寸 Dimensions (mm)						
	d	da	H1	H	T	L	螺孔数 n
63	65.00	11.50	52.00	155.00	15.00	250.00	12
75	77.00	11.50	62.00	172.10	16.00	280.00	12
90	92.00	13.50	71.50	205.00	18.00	320.00	12
110	112.00	13.50	86.00	234.00	18.00	340.00	12
125	128.00	13.50	96.00	257.00	20.00	360.00	12
140	142.00	13.50	102.34	260.82	20.00	338.00	14
160	162.00	13.50	119.50	299.00	20.00	380.00	14
180	182.00	13.50	132.00	332.30	22.00	432.00	16
200	202.00	13.50	150.40	349.70	22.00	460.00	18
225	228.00	13.50	163.00	388.00	23.00	460.00	14
250	254.00	13.50	187.20	440.00	23.00	480.00	18
280	282.00	13.50	194.50	458.00	23.50	480.00	18
315	317.00	13.50	226.00	520.00	30.00	480.00	20
355	357.50	13.50	251.50	570.00	35.00	530.00	24
400	402.00	13.50	271.30	606.60	34.00	540.00	22
500	500.00	13.50	327.50	758.50	37.50	675.00	22

产品参数

尺寸 Size De	外形尺寸 Dimensions (mm)		
	D0	D1	L
110	218.50	110.42	303.00
160	285.00	160.62	350.00
200	340.00	200.90	435.00
225	340.00	226.02	429.00
250	395.00	251.15	464.00

SADDLE CLAMP

增接口

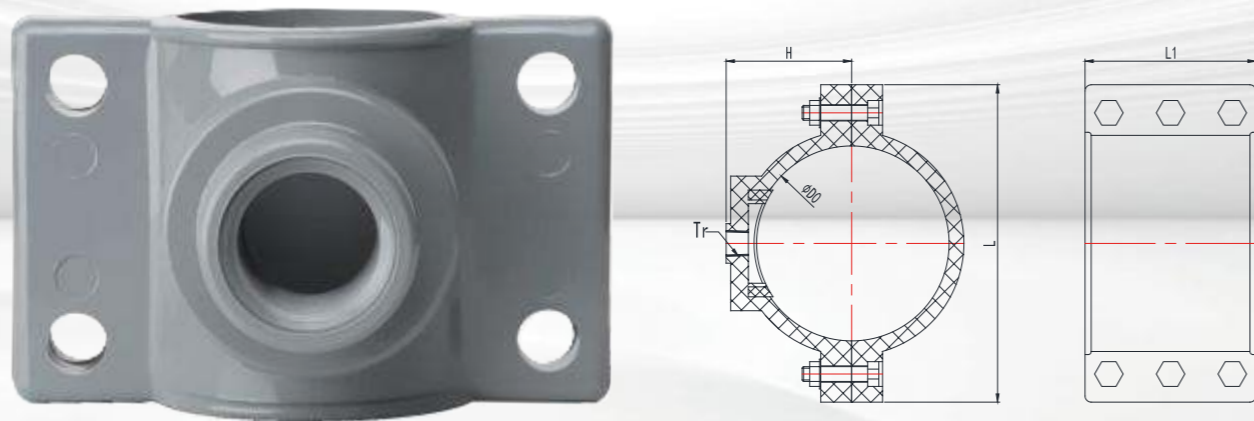

产品参数

尺寸 Size De	外形尺寸 Dimensions (mm)						公称压力 Nominal Pressure PN(kg/cm ²)
	D0	H	L	L1	Tr 螺纹	螺丝尺寸	
63*1"	63.00	65.30	138.50	89.30	1"	M12*40	10
75*1"	75.00	63.50	143.50	89.30	1"	M12*40	10
75*1-1/2"	75.00	63.50	143.50	89.30	1-1/2"	M12*40	10
90*1/2"	90.00	74.00	159.70	68.00	1/2"	M12*40	10
90*3/4"	90.00	74.00	159.70	68.00	3/4"	M12*40	10
90*1"	90.00	74.00	159.70	68.00	1"	M12*40	10
90*1-1/2"	90.00	74.00	159.70	89.50	1-1/2"	M12*40	10
110*1/2"	110.00	78.00	198.00	109.50	1/2"	M16*50	10
110*3/4"	110.00	78.00	200.00	109.50	3/4"	M16*50	10
110*1"	110.00	81.00	198.00	109.50	1"	M16*50	10
110*1-1/2"	110.00	91.00	199.00	108.00	1-1/2"	M16*50	10
110*2"	110.00	91.00	198.00	109.50	2"	M16*50	10
110*2-1/2"	110.00	91.00	198.00	109.50	2-1/2"	M16*50	10
125*1-1/2"	125.00	99.00	225.00	110.00	1-1/2"	M16*55	10
125*2"	125.00	99.00	225.00	110.00	2"	M16*55	10
125*2-1/2"	125.00	99.00	225.00	110.00	2-1/2"	M16*55	10
160*3/8"	160.00	104.50	253.00	120.00	3/8"	M16*55	10
160*1/2"	160.00	104.50	253.00	120.00	1/2"	M16*55	10
160*3/4"	160.00	104.50	253.00	120.00	3/4"	M16*55	10
160*1"	160.00	104.50	253.00	120.00	1"	M16*55	10
160*1-1/2"	160.00	118.50	253.00	120.00	1-1/2"	M16*55	10
160*2"	160.00	114.00	253.00	120.00	2"	M16*55	10
160*2-1/2"	160.00	118.50	253.00	120.00	2-1/2"	M16*55	10
200*1-1/2"	200.00	135.00	317.00	130.00	1-1/2"	M20*70	10
200*2"	200.00	138.00	317.00	130.00	2"	M20*70	10
200*2-1/2"	200.00	140.00	317.00	130.00	2-1/2"	M20*70	10
225*1/2"	225.00	150.00	335.00	140.00	1/2"	M20*70	10
225*1-1/2"	225.00	150.00	335.00	140.00	1-1/2"	M20*70	10
225*2"	225.00	152.00	335.00	140.00	2"	M20*70	10
225*2-1/2"	225.00	168.00	335.00	140.00	2-1/2"	M20*70	10
250*2"	250.00	170.00	351.00	141.00	2"	M20*80	10
250*2-1/2"	250.00	170.00	351.00	141.00	2-1/2"	M20*80	10
250*3"	250.00	170.00	351.00	141.00	3"	M20*80	10
315*110	315.00	240.00	467.00	160.00	-	M20*90	10
315*160	315.00	247.00	467.00	238.00	-	M20*90	10
315*2"	315.00	200.00	472.00	158.00	2"	M20*90	10
315*3"	315.00	205.00	472.00	158.00	3"	M20*90	10
315*4"	315.00	205.00	472.00	158.00	4"	M20*90	10
400*200	400.00	320.00	545.00	275.00	-	M20*90	6

阀门 VALVES



SOCKET BALL VALVE

插口球阀

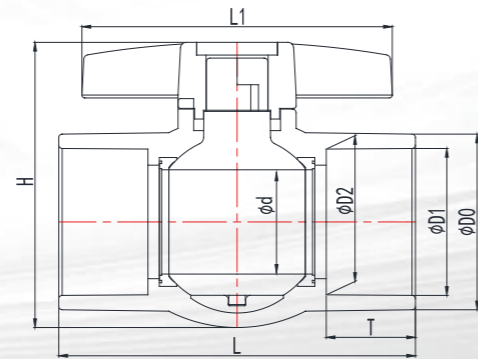

产品介绍

阀门描述 Valve description

1. 材质: UPVC
Material: UPVC
2. 尺寸: De20-110
Size: De20-110
3. 标准: 国标
Standard: DIN
4. 连接: 插口
Connection: socket
5. 颜色: 把手红色, 本体: 深灰
Color: handle red, body: dark gray

产品特性 Product Features

1. 符合饮用水标准
Meet drinking water standards
2. 开关扭力小
Switch torque is small
3. 简单经济
Simple economy
4. 材料经过纳米改性, 提高产品的耐压性及抗冲击性
The material is nano-modified to improve the pressure resistance and impact resistance of the product
5. 阀体加厚处理, 抗压性能高
Thickened valve body for high compression resistance
6. 阀门出厂 100% 压力测试
100% Pressure test for valve before leaving factory

产品参数

尺寸 Size Dn(De)	外形尺寸 Dimensions (mm)								公称压力 Nominal Pressure PN(kg/cm ²)
	D0	D1	D2	d	T	H	L1	L	
20	30.00	20.24	19.96	15.00	17.00	60.00	70.00	74.00	10
25	34.00	25.24	24.95	20.00	19.50	68.00	80.00	85.00	10
32	42.00	32.25	31.95	25.00	23.00	80.00	92.00	98.00	10
40	50.00	40.28	39.95	30.00	27.00	90.00	112.00	112.50	10
50	61.00	50.33	49.94	34.00	32.00	105.00	114.00	128.00	10
63	74.00	63.34	62.93	45.00	38.50	123.00	134.00	154.00	10
75	87.00	75.35	74.93	55.00	44.50	156.00	190.00	176.00	10
90	103.00	90.38	89.93	67.00	52.00	178.00	220.00	203.00	10
110	128.50	110.42	109.92	93.00	62.00	208.50	250.00	260.00	10

序号 No.	名称 Name	数量 Quantity	材料 Material
01	手柄 Handle	1	UPVC
02	商标盖 Mark cap	1	UPVC
03	球心 Ball	1	PP
04	阀体 Valve Body	1	UPVC
05	O型圈 O-ring	1	NR
06	止泻圈 Ball Seat	2	TPE

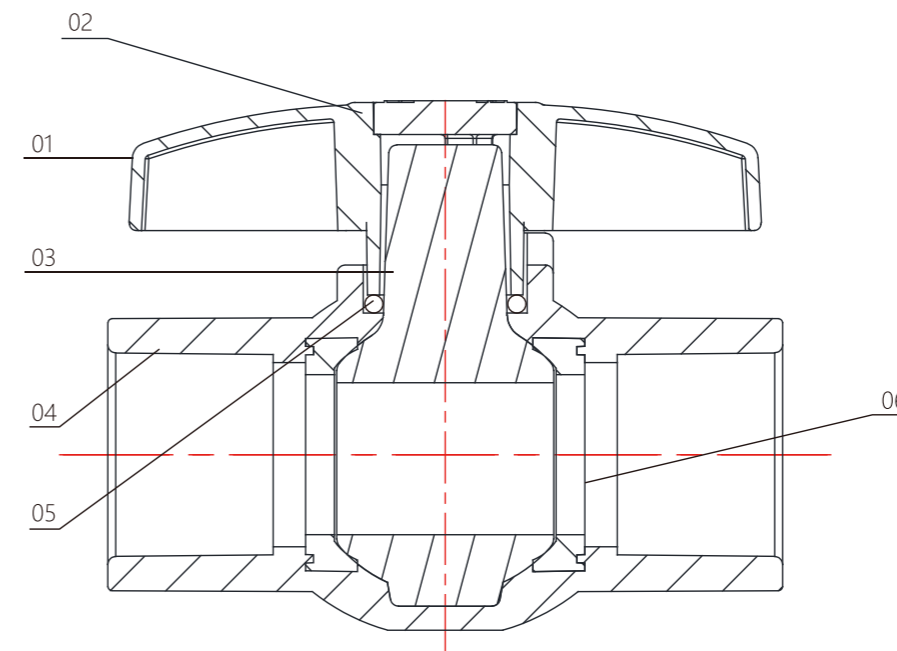

THREADED BALL VALVE

丝口球阀



产品介绍

阀门描述 Valve description

1. 材质: UPVC
Material: UPVC
2. 尺寸: De20-110
Size: De20-110
3. 标准: 国标
Standard: DIN
4. 连接: 螺纹
Connection: screw thread
5. 颜色: 把手红色, 本体: 深灰
Color: handle red, body: dark gray

产品特性 Product Features

1. 符合饮用水标准
Meet drinking water standards
2. 开关扭力小
Switch torque is small
3. 简单经济
Simple economy
4. 材料经过纳米改性, 提高产品的耐压性及抗冲击性
The material is nano-modified to improve the pressure resistance and impact resistance of the product
5. 阀门出厂 100% 压力测试
100% Pressure test for valve before leaving factory

产品参数

尺寸 Size Dn(De)	外形尺寸 Dimensions (mm)									公称压力 Nominal Pressure PN(kg/cm ²)
	D0	D1	D2	d	T	H	L1	L	Tr 螺纹	
20*1/2"	31.60	18.76	18.35	15.00	17.00	60.00	70.00	74.00	1/2"	10
25*3/4"	37.70	24.10	23.90	20.00	19.50	68.00	80.00	85.00	3/4"	10
32*1"	45.50	31.00	30.70	25.00	23.00	80.00	92.00	98.00	1"	10
40*1-1/4"	54.80	39.60	39.10	30.00	27.00	90.00	112.00	112.50	1-1/4"	10
50*1-1/2"	62.00	45.00	44.50	34.00	32.00	105.00	114.00	128.00	1-1/2"	10
63*2"	74.80	56.60	56.10	45.00	36.00	123.00	134.00	149.00	2"	10
75*2-1/2"	92.20	72.20	71.96	55.00	40.00	156.00	190.00	168.00	2-1/2"	10
90*3"	106.70	85.10	84.40	67.00	48.00	178.00	220.00	195.00	3"	10
110*4"	135.20	110.00	109.50	93.00	54.00	208.50	250.00	244.00	4"	10

序号 No.	名称 Name	数量 Quantity	材料 Material
01	手柄 Handle	1	UPVC
02	商标盖 Mark cap	1	UPVC
03	球心 Ball	1	PP
04	阀体 Valve Body	1	UPVC
05	O型圈 O-ring	1	NR
06	止泻圈 Ball Seat	2	TPE

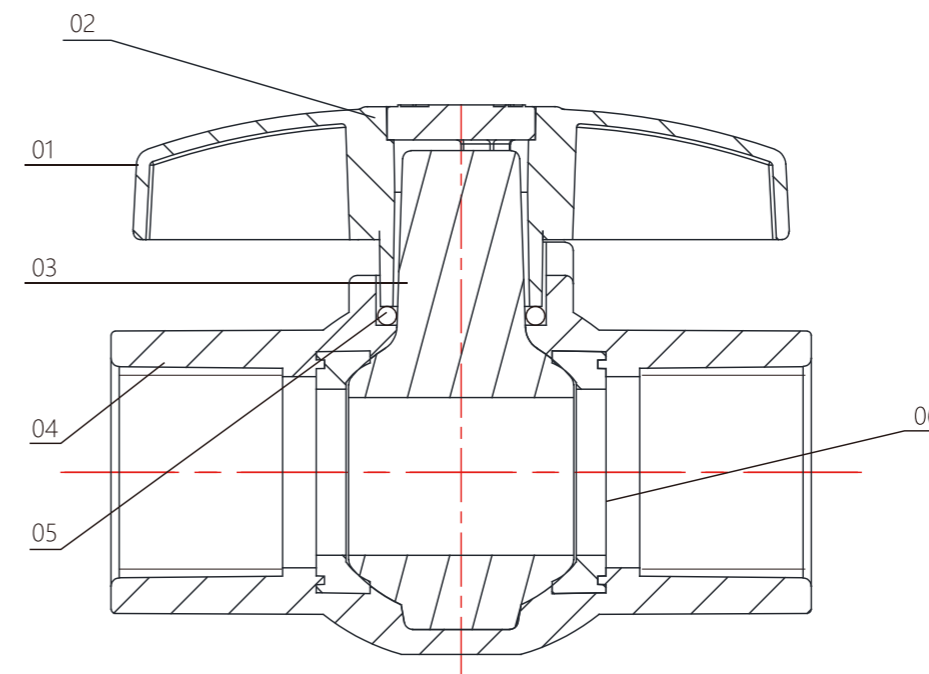

GENERAL BUTTERFLY VALVE (HANDLED TYPE)

手动通用蝶阀

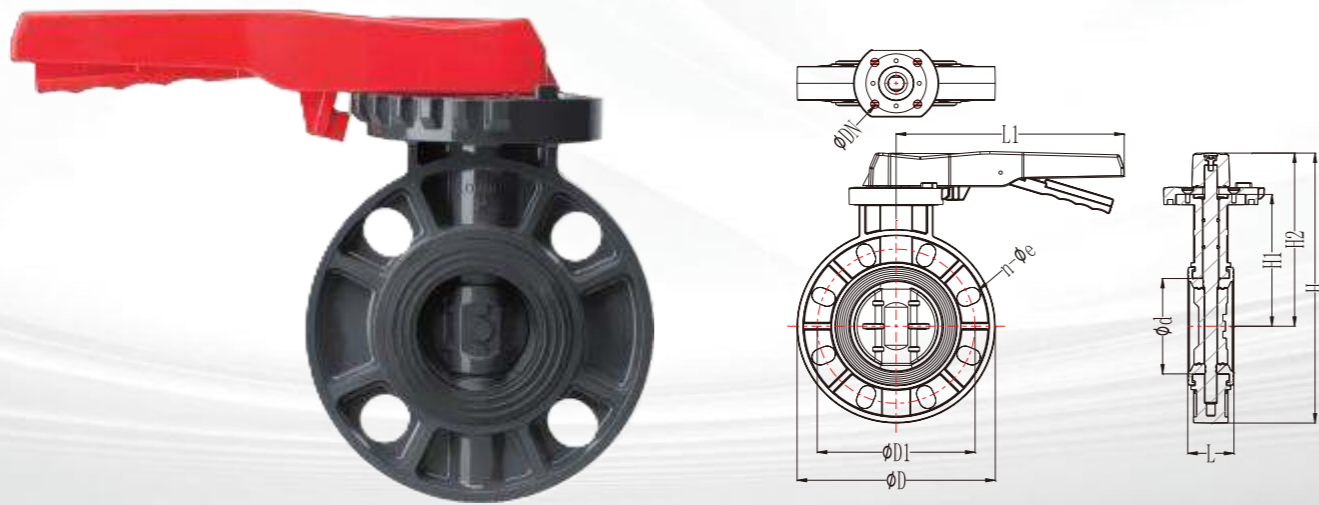

产品介绍

阀门描述 Valve description

1. 材质: UPVC
Material: UPVC
2. 尺寸: DN50-200
Size: DN50-200
3. 标准: 国标
Standard: DIN
4. 连接: 法兰
Connection: flange
5. 颜色: 把手红色, 本体: 深灰
Color: handle red, body: dark gray

产品特性 Product Features

1. 符合饮用水标准
Meet drinking water standards
2. 开关扭力小
Switch torque is small
3. 简单经济
Simple economy
4. 材料经过纳米改性, 提高产品的耐压性及抗冲击性
The material is nano-modified to improve the pressure resistance and impact resistance of the product
5. 阀门出厂 100% 压力测试
100% Pressure test for valve before leaving factory

产品参数

尺寸 Size Dn(De)	外形尺寸 Dimensions (MM)										公称压力 Nominal Pressure PN(kg/cm ²)
	D	D1	d	L	DN	L1	H1	H2	H	n-φe	
50(63)	159.50	125.00	62.20	39.00	70.00	215.80	99.45	143.35	223.00	4-19	10
65(75)	180.00	145.00	78.70	36.00	70.00	215.80	111.50	155.40	245.40	4-19	10
80(90)	196.00	160.00	92.10	42.00	70.00	215.80	127.00	170.90	268.90	8-19	10
100(110)	229.60	180.00	111.90	46.00	70.00	264.20	156.25	205.15	320.00	8-19	10
125(140)	255.00	210.00	137.90	53.00	70.00	264.20	174.00	222.90	350.40	8-19	10
150(160)	281.50	240.00	157.35	59.40	70/102	305.40	190.00	250.60	391.35	8-23	10
200(225)	342.60	295.00	214.20	76.00	70/102	303.27	229.00	280.60	460.90	8-23	10

序号 No.	名称 Name	数量 Quantity	材料 Material
01	阀体 Valve body	1	PVC-U
02	阀座 Seat seal	1	NR
03	阀板 Disc	1	PVC-U
04	O型圈 O-ring	2	NR
05	齿轮盘 Plate	1	PVC-U
06	手柄 Handle	1	PVC-U
07	副把 Lever	1	PVC-U
08	销钉 Set pin	1	STEEL
09	商标盖 Logo cap	1	PVC-U
10	螺丝 Screw	1	STEEL
11	阀杆 Shaft	1	STEEL

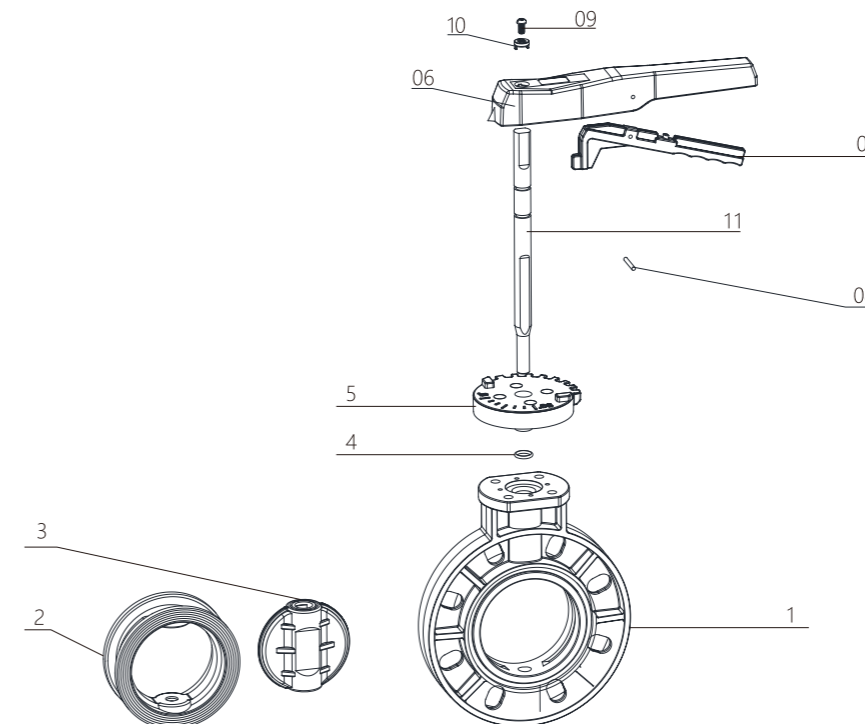

EXPERT IN PIPING SYSTEM

管路系统的专家级工厂



微信公众号二维码



企业网站二维码

 **400-928-1588**

华生管道科技有限公司

地址：常州市新北区空港产业园旺贤路9号(213133)
电话：+86 519-85201808 83201080
传真：+86 519-83201088 83201026
邮箱：sales@czhuasheng.com
info@czhuasheng.com
网址：www.czhuasheng.com

HUASHENG PIPELINE TECHNOLOGY CO., LTD

Add: NO9, Wangxian Road, Konggang Industry Park, Xinbei District, Changzhou, 213133, China
Tel: +86 519-85201808 83201080
Fax: +86 519-83201088 83201026
Email: sales@czhuasheng.com
info@czhuasheng.com
Web: www.huashengpipe.com